



MATH 0212 ELEMENTARY INTEGRAL CALCULUS

VLADIMIR V. KISIL

- MODULE SUMMARY. • The concept of integration as anti-differentiation, and the fundamental theorem of the calculus.
- Indefinite and definite integrals. Area under a curve.
 - Techniques of integration, including by substitution, by parts and by partial fractions.
 - Applications of integration, including volumes of revolution.
 - Binomial theorem, Pascal’s triangle, sine and cosine rules.
 - Revision: Sine and cosine rules, equations of circles.

CONTENTS

List of Figures	2
1. Integration	3
1.1. Riemann Integral	4
1.2. Fundamental Theorem of Calculus	8
1.3. Powers of x	10
1.4. Trigonometric Functions	11
1.5. Exponential Function	12
1.6. Logarithmic Function	13
2. Methods of integrations	15
2.1. Change of Variable (Substitution)	15
2.2. Other Trigonometric Integrals	18
2.3. Integration by Parts	19
2.4. Rational functions and partial fractions	21
2.5. Trigonometric t Substitution	27
2.6. Inverse Trigonometric Functions	28
3. Hyperbolic functions	31
3.1. Hyperbolic functions and exponent	31
3.2. Inverse hyperbolic functions	33
3.3. Summary of useful substitutions	36
4. Applications of integrals	36
4.1. Areas	36
4.2. Volumes	41
5. Binomial Coefficients and Polynomials	44
5.1. Binomial Coefficients	44

5.2. Pascal's Triangle	46
5.3. The Binomial Theorem	47
6. Some revision examples	48
6.1. Polynomial Division	49
6.2. Various examples	50
Appendix A. Triangles	52
A.1. Area of a Triangle	52
A.2. Sine Rule	53
A.3. Cosine Rule	54
A.4. Circles	56
Index	57
References	59

LIST OF FIGURES

1 Area of a circle	4
2 Integration	4
3 Estimating area by rectangles for a monotonic function. Larger number of rectangles produces a smaller error.	6
4 For a function with negative values the integral equal to the area "under" the graph taken with appropriate signs.	7
5 Fundamental theorem of calculus	9
6 Equal areas under the graphs	13
7 Inverse trigonometric functions	29
8 Graphs of hyperbolic functions.	32
9 Area of a circle	37
10 Circular strip	38
11 Area of an ellipse	38
12 Area under the graph of sine	39
13 Area under a parabola	40
14 Area under a curve	40
15 Integration of rotation solids	41
16 Volume of a cone	41
17 Volume of a sphere	42
18 Volume of a pyramid	43
19 A triangle and notations	52
20 Basic relations in a triangle.	52
21 Relation between sides and cosines.	54

Recommended book

L. Bostock and S. Chandler, *Core Maths for A-level*. Stanley Thornes (Publishers) Ltd, 3rd Edition 2000.

Advanced reading

M. Spivak, *Calculus*. Cambridge University Press: 3rd edition, 2006.

Supplementary reading

Pólya, *How to Solve It*. Princeton N.J. ; Oxford : Princeton University Press, 2004.

1. INTEGRATION

Integration is the problem of determining areas and, as we shall see later, volumes. For a polygon this problem can be solved purely geometrically if we decompose the polygon into disjoint triangles. In general *area* is characterised by the following properties:

- Axiom 1.1** (Axioms of area). (1) An area of a figure is a non-negative real number.
 (2) If a figure is a union of several disjoint (non-overlapping) parts, then area of the figure is equal to the sum of its parts' areas.

It is easy to derive from these two properties that *the area of a figure is bigger than the area of any part*. Furthermore, we assume that

Any two equal figures has the same area. (Figures are equal if one can be obtained from another by motions of the plain: shifts, rotations and reflections)

A square of the unit area—say 1 cm^2 —can be divided into 100 equal small squares. By the previous assumptions each of smaller squares has the area 0.01 cm^2 . Using elementary “cut-and-glue” techniques we can derive areas of some basic shapes:

- (1) Area of a *rectangle* is the product of its sides: $S = ab$.
- (2) Area of a *parallelogram* is the product of its base and height: $S = bh$.
- (3) Area of a *triangle* is half of the product of its base and height: $S = \frac{1}{2}ah$.

However, for curved shapes we need a kind of limit procedures.

Example 1.2. Suppose we want the area of a circle dividing it into n equal triangles shown on Fig. 1. Area of the triangle is

$$A_t = \frac{1}{2} \text{base} \times \text{height},$$

where the height is approximately R and that approximation is more accurate for larger n . Also for large n the sum of all triangles' bases is the length of the circle, that is 2π .

$$A = nA_t \simeq \frac{1}{2}R \cdot 2\pi R = \pi R^2.$$

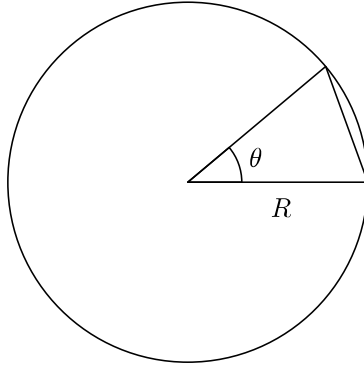

FIGURE 1. Area of a circle

If we let $n \rightarrow \infty$, then $\theta \rightarrow 0$, which means the approximation for A_t becomes exact. The sum of the areas of the triangles also becomes equal to the area of the circle. Hence the area of the circle is $A = \pi R^2$.

A similar ideas can be applied to figures of arbitrary shape as explained below.

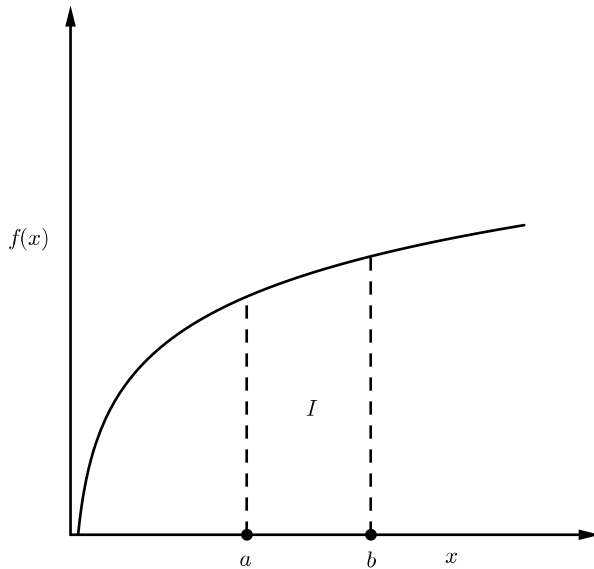

FIGURE 2. Integration

1.1. Riemann Integral. Let $f(x)$ be a function of a real variable *taking positive values*.

Definition 1.3. Let I be the area under the graph of $f(x)$ shown on Fig. 2. Then we introduce the *definite integral* by

$$(1) \quad \int_a^b f(x) \, dx = I.$$

An immediate consequence of the Defn. 1.3 and Axiom 1.1 is:

Proposition 1.4. For a function $f(x)$ defined on adjacent intervals $[a, b]$ and $[b, c]$ we have:

$$(2) \quad \int_a^c f(x) \, dx = \int_a^b f(x) \, dx + \int_b^c f(x) \, dx.$$

Now we describe a procedure to evaluate a definite interval. Divide the interval $a \leq x \leq b$ into n parts $x_k \leq x \leq x_{k+1}$, with

$$x_k = a + \frac{k}{n}(b - a), \quad \text{for } k = 0, 1, \dots, n.$$

See Fig. 3 for illustration. Write

$$\delta x = \frac{b - a}{n}.$$

We can now work out

$$(3) \quad \sum_{k=0}^{n-1} f(x_k) \cdot \delta x,$$

and this has a limit written as

$$\int_a^b f(x) \, dx$$

when n goes to infinity. For the existence of the limit (and the definite integral) the function shall not jump too much on small intervals. This can be seen from Fig. 3, which gives the upper and lower estimations of the area above the interval δx .

Consider a *monotonically increasing* function $f(x)$, cf. Fig. 3. Then

In Fig. 3 left, area of rectangle shown is $\delta I_k^l = (x_{k+1} - x_k)f(x_k) = \delta x f(x_k)$,

In Fig. 3 right, area of rectangle shown is $\delta I_k^u = (x_{k+1} - x_k)f(x_{k+1}) = \delta x f(x_{k+1})$.

Define

$$(4) \quad I_n^l = \sum_{k=0}^{n-1} \delta I_k^l = \sum_{k=0}^{n-1} f(x_k) \cdot \delta x,$$

$$I_n^u = \sum_{k=0}^{n-1} \delta I_k^u = \sum_{k=0}^{n-1} f(x_{k+1}) \cdot \delta x,$$

Since $f(x)$ is increasing, we certainly have

$$I_n^l \leq I \leq I_n^u$$

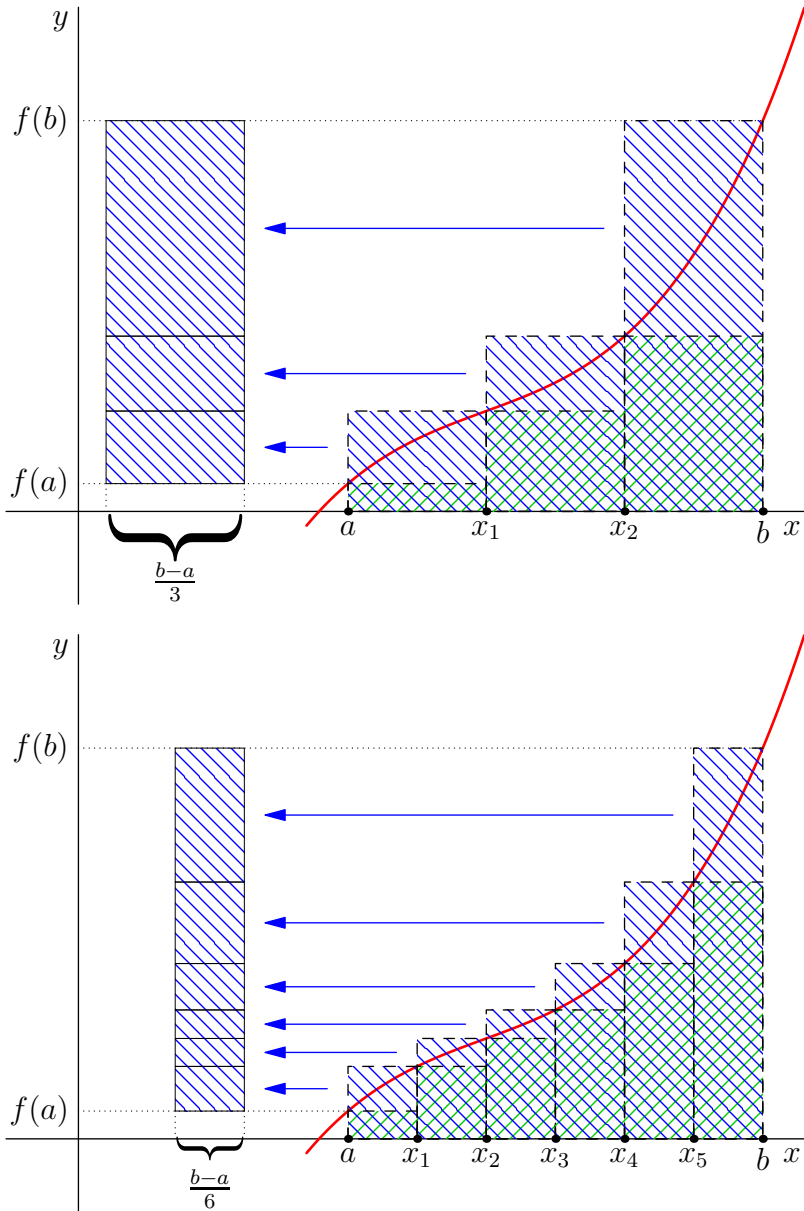

FIGURE 3. Estimating area by rectangles for a monotonic function. I_n^u is the area shadowed by the blue (NW) strokes, I_n^l is the area double shadowed by green (NE) strokes. $I_n^u - I_n^l$ is equal to the area of the rectangle on the left (shadowed by blue (NW) strokes). A larger number of small intervals produces a smaller error $I_n^u - I_n^l$.

As $n \rightarrow \infty$ we have $\delta x \rightarrow 0$ and we expect $I_n^l \rightarrow I_n^u$ and $I_n^l \rightarrow I$ i.e. $\lim_{n \rightarrow \infty} I_n^l = \lim_{n \rightarrow \infty} I_n^u = I$. Indeed:

$$I_n^u - I_n^l = \sum_{k=0}^{n-1} f(x_{k+1}) \cdot \delta x - \sum_{k=0}^{n-1} f(x_k) \cdot \delta x = (f(b) - f(a)) \cdot \delta x.$$

Informally: the difference is equal to the area of the rectangle with height $f(b) - f(a)$ and width δx as shown on Fig. 3. Thus $(I_n^u - I_n^l) \rightarrow 0$ if $\delta x \rightarrow 0$.

A similar estimation is possible for a function $f(x)$ which may not be monotonic but does not “jump up&down” too much.

Definition 1.5. The above limiting value of the sum (3) is called the *Riemann integral*. The process of finding integral is called *integration*.

Recall, that the defined integral was linked to the area for a positive function $f(x)$. However, the formula (3) suggests a modification of the definition for functions taking any values. Indeed, in (3) negative values $f(x_k)$ of the functions produce areas of rectangles with the opposite sign. Thus, in a definite integrals areas between the graph of $f(x)$ and the horizontal axis is counted with the sign of $f(x)$ on the corresponding sub-intervals, see Fig. 4.

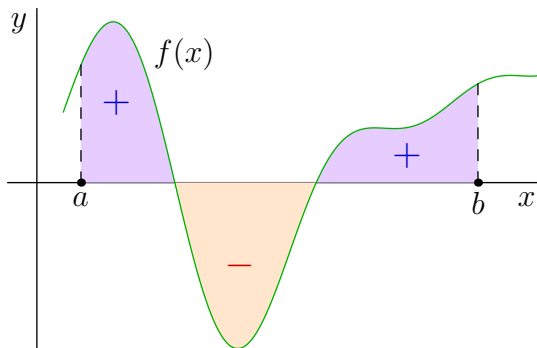

FIGURE 4. For a function with negative values the integral equal to the area “under” the graph taken with appropriate signs.

A definite integral could be calculated from the definition, but this is very difficult for all but the simplest functions.

Example 1.6. (1) The most elementary (but still important!) example is the constant function $f(x) = c$ for some constant number c . Then for any finite interval $[a, b]$ we have $x_k = a + k(b - a)/n$ and $\delta x = (b - a)/n$. Thus:

$$\sum_{k=0}^{n-1} f(x_k) \cdot \delta x = \sum_{k=0}^{n-1} c \frac{b - a}{n} = c(b - a) \sum_{k=0}^{n-1} \frac{1}{n} = c(b - a).$$

This is independent from n , thus has the same value $c(b - a)$ at the limit $n \rightarrow \infty$. Obviously, this is the area of the rectangle with the height c and the base $[a, b]$ of the length $b - a$.

(2) Suppose we have a triangle, given by

$$f(x) = x, \quad a = 0, \quad b = 1.$$

Then $\delta x = 1/n$, $x_k = k/n$. So the total area of the rectangles is

$$\sum_{k=0}^{n-1} f(x_k) \cdot \delta x = \sum_{k=0}^{n-1} \frac{k}{n} \frac{1}{n} = \frac{1}{n^2} \sum_0^{n-1} k.$$

But

$$\sum_0^{n-1} k = \sum_1^{n-1} k = \frac{(n-1)n}{2} \quad (\text{sum of an arithmetic series}).$$

Hence we get

$$\frac{1}{n^2} \frac{(n-1)n}{2} = \frac{1}{2} \left(1 - \frac{1}{n}\right) \rightarrow \frac{1}{2} \text{ as } n \rightarrow \infty.$$

This is correct since we have a triangle of height 1 and base 1.

(3) We may try to find $\int_0^1 x^2 dx$ in a similar fashion, this is indeed possible, see the second example classes. See also [method of exhaustion](#) for this problem proposed by [Archimedes](#) and re-discovered by [Ibrahim ibn Sinan](#) some centuries later.

Remark 1.7. In the above discussion we split $[a, b]$ into sub-intervals of the same size for simplicity only. For an efficient numerical approximation of an integral, points of the partition shall be spaced differently: we need more points where function changes its values rapidly and less points where the graph of the functions is almost flat.

From the above procedure for evaluation of a definite integral we can derive the following important properties.

Proposition 1.8. (1) For a function $f(x)$ defined on an interval $[a, b]$ and a constant c we have:

$$(5) \quad \int_a^b cf(x) dx = c \int_a^b f(x) dx.$$

(2) For functions $f(x)$ and $g(x)$ defined on an interval $[a, b]$ we have:

$$(6) \quad \int_a^b (f(x) + g(x)) dx = \int_a^b f(x) dx + \int_a^b g(x) dx.$$

[Compare identities (2) and (6) and notice the difference.]

(3) For a function $f(x)$ defined on an interval $[a, b]$ we let:

$$\int_b^a f(x) dx = - \int_a^b f(x) dx$$

and this agrees with (2).

1.2. **Fundamental Theorem of Calculus.** Barrow discovered that integration is the opposite process to differentiation, which makes it much easier to calculate integrals. However, this fundamental theorem is commonly attributed now to Newton (a student of Barrow) and Leibniz, who lay down foundations of modern analysis.

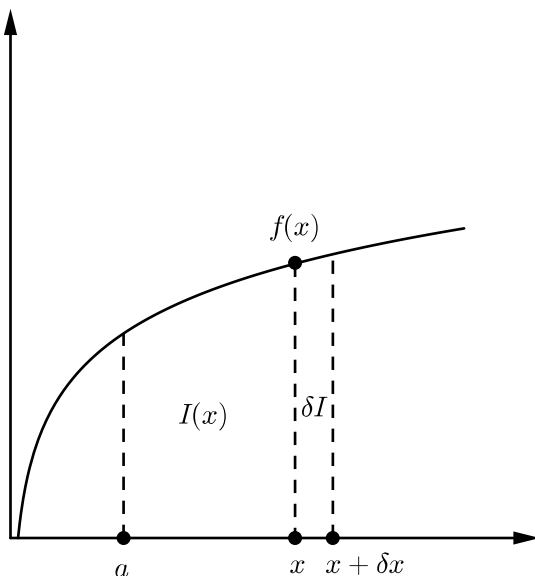

FIGURE 5. Fundamental theorem of calculus

Define $I(x)$ to be the area shown on Fig. 5. Have $\delta I \simeq f(x)\delta x$. From the definition of the derivative we have

$$\frac{dI}{dx} = \lim_{\delta x \rightarrow 0} \frac{I(x + \delta x) - I(x)}{\delta x} = \lim_{\delta x \rightarrow 0} \frac{\delta I}{\delta x} = f(x).$$

The **fundamental theorem of calculus** says that the definite integral is a substitution into indefinite integral:

$$(7) \quad \int_a^b f(x) dx = I(b) - I(a),$$

where $I(x)$ is a function that satisfies

$$(8) \quad \frac{dI}{dx} = f(x).$$

For convenience, we introduce the notation:

$$[I]_a^b = I(b) - I(a)$$

for substitution of function $I(x)$ from a to b . Using this notation (7) can be written as:

$$(9) \quad \int_a^b f(x) dx = [I]_a^b = I(b) - I(a),$$

Note that we can add an arbitrary constant to I without changing (8) or (9). Also, any two functions $I_1(x)$ and $I_2(x)$ with the same derivative $I_1'(x) = I_2'(x) = f(x)$ are different by a constant only: $I_1(x) = I_2(x) + c$.

In relation to definite integral (1), which is a real number, we also introduce:

Definition 1.9. The *indefinite integral* is a function, $I(x)$, that satisfies (8), i.e.

$$(10) \quad I(x) = \int f(x) dx \quad \text{is equivalent to} \quad \frac{dI}{dx} = f(x).$$

The indefinite integral is also called *anti-derivative* sometimes.

For all this to work, we have to consider the area to be negative if $f(x) < 0$ (since then the δI_k are negative from the definition), see Fig. 4.

Note, that for an indefinite integral we again have the rule similar to (6): a sum of functions is just the sum of the integrals i.e.

$$(11) \quad \int [f(x) + g(x)] dx = \int f(x) dx + \int g(x) dx.$$

This follows from the properties of the derivative

$$\frac{d}{dx}[F(x) + G(x)] = \frac{dF}{dx} + \frac{dG}{dx}, \quad \text{where} \quad F(x) = \int f(x) dx, \quad G(x) = \int g(x) dx.$$

Integrating gives (11). It also follows from the definition.

Similarly we can show for indefinite integrals the rule similar to (5):

$$(12) \quad \int cf(x) dx = c \int f(x) dx \quad \text{for any number } c \text{ and function } f(x).$$

1.3. Powers of x . Find $\int x^\alpha dx$ for some constant α . We want a function $F(x)$ so that $\frac{dF}{dx} = x^\alpha$.

From MATH 0111 we know that $\frac{d}{dx}x^\beta = \beta x^{\beta-1}$ for any β . So if we put $F(x) = Ax^{\alpha+1}$, we get

$$\frac{dF}{dx} = A(\alpha + 1)x^\alpha, \quad \text{i.e.,} \quad \frac{dF}{dx} = x^\alpha \quad \text{if} \quad A = \frac{1}{\alpha + 1}.$$

Hence

$$(13) \quad \int x^\alpha dx = \frac{1}{\alpha + 1}x^{\alpha+1} + C \quad (C \text{ is an arbitrary constant}).$$

This works both for $\alpha > 0$ and $\alpha < 0$, but goes wrong if $\alpha = -1$ (see § 1.6 later).

Example 1.10. (1) $\int x^2 dx$. We have $\alpha = 2$, so $\int x^2 dx = \frac{1}{3}x^3 + C$.

$$(2) \int x^{-2} dx. \text{ We have } \alpha = -2, \text{ so } \int x^{-2} dx = -\frac{1}{x} + C.$$

Now we can do a definite integral, to find the area of the triangle we started with.

This is

$$\int_0^1 x dx = \left[\frac{x^2}{2} \right]_0^1 = \frac{1^2}{2} - \frac{0^2}{2} = \frac{1}{2}.$$

This is what we got by summing up a series.

Similarly, for the area under a parabola $y = x^2$ from $x = 0$ to 3 , we get

$$\int_0^3 x^2 dx = \left[\frac{x^3}{3} \right]_0^3 = \frac{3^3}{3} - \frac{0^3}{3} = 9.$$

1.4. Trigonometric Functions. We can find integrals of trigonometric functions as follows.

1.4.1. *Sine.* $\int \sin x dx$. We know that $\frac{d}{dx} \cos x = -\sin x$. Hence

$$\int \sin x dx = -\cos x + C.$$

Suppose we have $\int \sin(ax) dx$ with a a constant.

Recall the *Chain Rule* for differentiation from MATH0111

$$(14) \quad \frac{d}{dx} f[g(x)] = \frac{df}{dg} \frac{dg}{dx}.$$

for any functions $f(g)$, $g(x)$.

Put $f(g) = \cos g$, $g(x) = ax + b$ so that $f = \cos(ax + b)$. Then (14) gives

$$\frac{d}{dx} \cos(ax + b) = \frac{d}{dx} f[g(x)] = \frac{d(\cos g)}{dg} \frac{d(ax + b)}{dx} = -a \sin g = -a \sin(ax).$$

We therefore have

$$(15) \quad \int \sin(ax + b) dx = -\frac{1}{a} \cos(ax + b) + C.$$

1.4.2. *Cosine.* $\int \cos x dx$. We know that $\frac{d}{dx} \sin x = \cos x$. Hence

$$\int \cos x dx = \sin x + C.$$

Again using the Chain Rule we have

$$(16) \quad \int \cos(ax + b) dx = \frac{1}{a} \sin(ax + b) + C.$$

Example 1.11. (1) $\int \sin(3x) \, dx$. Then $a = 3$ and (15) gives

$$\int \sin(3x) \, dx = -\frac{1}{3} \cos(3x) + C.$$

(2) $\int \cos(x/2) \, dx$. Then $a = 1/2$ and (16) gives

$$\int \cos(x/2) \, dx = 2 \sin(x/2) + C.$$

$$(3) \int_0^{\pi/6} \sin(3x) \, dx = \left[-\frac{1}{3} \cos(3x) \right]_0^{\pi/6} = -\frac{1}{3} \cos \frac{\pi}{2} + \frac{1}{3} \cos 0 = \frac{1}{3}.$$

(4) Try to independently integrate both sides of the identity $\cos(x) = \sin(\frac{\pi}{2} - x)$. Will you receive the same answer in both cases?

1.5. Exponential Function. $\int e^x \, dx$. Here, $e = 2.718281828 \dots$ is the Euler's constant.

We know that $\frac{d}{dx} e^x = e^x$.

As for Sine and Cosine, we want $\int e^{ax+b} \, dx$ for any constant a .

Using the Chain Rule (14) with $f(g) = e^g$, $g(x) = ax + b$ so that $f = e^{ax+b}$, gives

$$\frac{d}{dx} e^{ax+b} = \frac{d}{dx} f[g(x)] = \frac{d(e^g)}{dg} \frac{d(ax+b)}{dx} = ae^g = ae^{ax+b}.$$

So

$$(17) \int e^{ax+b} \, dx = \frac{1}{a} e^{ax+b} + C.$$

Note, that alternatively we can obtain the same answer from the exponent rules: $e^{ax+b} = e^b e^{ax}$.

Example 1.12. (1) $\int e^{2x} \, dx$. Then $a = 2$ and (17) gives

$$\int e^{2x} \, dx = \frac{1}{2} e^{2x} + C.$$

(2) $\int e^{x/3} \, dx$. Then $a = 1/3$ and (17) gives

$$\int e^{x/3} \, dx = 3e^{x/3} + C.$$

(3) $\int 2^x \, dx$. Since $2 = e^{\ln 2}$ and $2^x = e^{(\ln 2)x}$ we can use the previous formula with $a = \ln 2$ and (17) gives

$$\int 2^x \, dx = \int e^{(\ln 2)x} \, dx = \frac{1}{\ln 2} e^{(\ln 2)x} + C = \frac{1}{\ln 2} 2^x + C.$$

Similarly, in general we can check that $\int a^x dx = \frac{1}{\ln a} a^x + C$.

$$(4) \int_1^2 e^{2x} dx = \left[\frac{1}{2} e^{2x} \right]_1^2 = \frac{e^4}{2} - \frac{e^2}{2}.$$

(5) Evaluate similarly that $\int_{-a}^0 e^x dx = [e^x]_{-a}^0 = e^0 - e^{-a}$. Note that this is the area under the graph of e^x over $[-a, 0]$. Now if $(-a) \rightarrow -\infty$, then this area tends to 1 since $e^{-a} \rightarrow 0$. Thus the area of the infinite region over the half-line $(-\infty, 0)$ is the finite number!

(6) Note, that $e^{ax+b} = e^{ax} e^b = k e^{ax}$ for $k = e^b$. Then we can make the calculation:

$$\int e^{ax+b} dx = \int k e^{ax} dx = k \int e^{ax} dx = \frac{k}{a} e^{ax} + C = \frac{1}{a} e^b e^{ax} + C = \frac{1}{a} e^{ax+b} + C,$$

again the same answer as expected.

1.6. Logarithmic Function. We wish to consider the indefinite integral of the function $f(x) = 1/x$ which was not treated in Sect. 1.3. Let us start from a comparison of two definite integrals:

$$\int_1^2 \frac{1}{x} dx \quad \text{and} \quad \int_3^6 \frac{1}{x} dx.$$

Consider Fig. 6 which approximate each of these integrals by areas of three rectangles. It

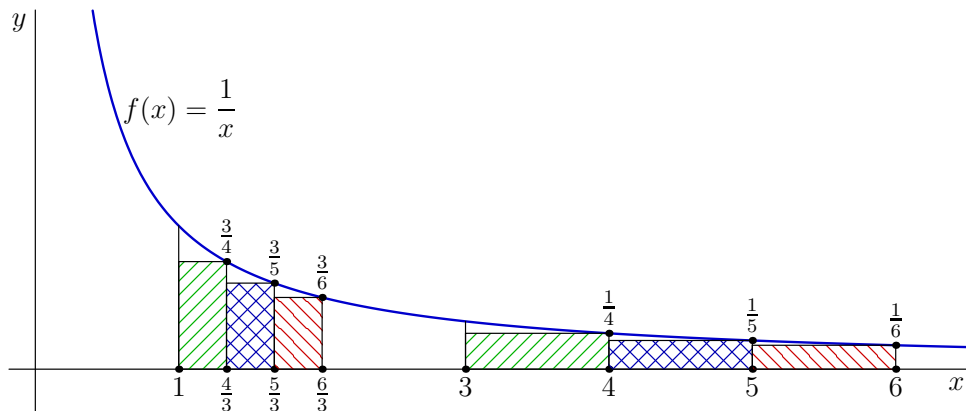

FIGURE 6. Similarly shaded rectangles under the graph have equal areas: the bases of right rectangles are three times wider but the left rectangles are three times taller.

turns out that respective (similarly shaded) rectangles under the graph have equal areas: the right rectangles are three times wider but the left respective rectangles are three times taller. And this can be shown for any number of rectangles covering the areas under the

graph. Thus:

$$\int_1^2 \frac{1}{x} dx = \int_3^6 \frac{1}{x} dx = \int_{3 \cdot 1}^{3 \cdot 2} \frac{1}{x} dx.$$

More generally we can prove (see Example 2.2 below) that:

$$(18) \quad \int_a^b \frac{1}{x} dx = \int_{ka}^{kb} \frac{1}{x} dx \quad \text{for any number } k.$$

Now we define a function $L(t) = \int_1^t \frac{1}{x} dx$. Then:

$$\begin{aligned} L(ab) &= \int_1^{ab} \frac{1}{x} dx && \text{(by definition of } L(t)) \\ &= \int_1^a \frac{1}{x} dx + \int_a^{ab} \frac{1}{x} dx && \text{(by (2))} \\ &= \int_1^a \frac{1}{x} dx + \int_1^b \frac{1}{x} dx && \text{(by (18))} \\ &= L(a) + L(b). && \text{(by definition of } L(t)) \end{aligned}$$

Thus, function $L(t)$ *behaves like* logarithm! We will see now that *it is* logarithm.

In order to define this, we need the idea of an *inverse function*. Suppose we have a function $f(x)$. Then we define the inverse function f^{-1} by

$$(19) \quad y = f(x) \quad \Rightarrow \quad x = f^{-1}(y).$$

We now define *logarithmic function*, $\ln x$, as the inverse of the exponential function; *i.e.*,

$$(20) \quad y = \ln(x) \quad \Rightarrow \quad e^y = x \quad \text{or} \quad x = e^{\ln(x)},$$

provided $x > 0$ (since $e^y > 0$ for all y).

We know that the exponential function has the property

$$(21) \quad e^x e^y = e^{x+y},$$

for any x, y . From (20) we then have

$$xy = e^{\ln(x)} e^{\ln(y)} = e^{\ln(x) + \ln(y)} = e^{\ln(xy)};$$

i.e.,

$$(22) \quad \ln(xy) = \ln(x) + \ln(y).$$

If we differentiate (20) we get

$$e^y \frac{dy}{dx} = x \frac{dy}{dx} = 1.$$

Hence

$$(23) \quad \frac{d}{dx} \ln(x) = \frac{1}{x}.$$

for any $x > 0$. Using the chain rule you can show that if $x < 0$, then

$$\frac{d}{dx} \ln(-x) = \frac{1}{x}.$$

Recalling that *modulus* or *absolute value* is:

$$|x| = \begin{cases} x & x \geq 0, \\ -x & x < 0, \end{cases}$$

we can combine these statements as

$$\frac{d}{dx} \ln|x| = \frac{1}{x}.$$

This means that

$$(24) \quad \int \frac{dx}{x} = \ln|x| + C.$$

Example 1.13.

$$\int_{-e}^{-1} \frac{dx}{x} = [\ln|x|]_{-e}^{-1} = \ln 1 - \ln e = 0 - 1 = -1.$$

Remember that our equation (13),

$$\int x^\alpha dx = \frac{1}{1+\alpha} x^{1+\alpha} + C \quad (C \text{ is an arbitrary constant}).$$

failed when $\alpha = -1$. We can now see that in this case the integral is $\ln|x|$.

2. METHODS OF INTEGRATIONS

Different integrals require different methods. We will describe several most general approaches.

2.1. Change of Variable (Substitution). Assume that $x = g(t)$ for an independent variable t and a function $g(t)$. Differentiation and the chain rule give:

$$(25) \quad \frac{dx}{dt} = \frac{dg(t)}{dt} \quad \text{or} \quad dx = \frac{dg(t)}{dt} dt = g'(t) dt.$$

Let we have a function $f(x)$ and its indefinite integral $F(x)$, that is $\frac{dF(x)}{dx} = f(x)$. From the chain rule, (14), have

$$(26) \quad \frac{d}{dt} F[g(t)] = \frac{dF}{dx} \frac{dg}{dt} = f(g(t)) g'(t).$$

Integrating (26) w.r.t. t and using (25) gives

$$F[g(t)] = \int f(g(t)) g'(t) dt = \int f(x) dx = F(x), \quad \text{because } dx = g'(t) dt \text{ and } x = g(t).$$

We also used that integration is the inverse of differentiation.

Thus we obtained the formula for *change of variable* in an indefinite integral:

$$(27) \quad \int f(g(t)) \frac{dg(t)}{dt} dt = \int f(x) dx$$

Note, that for a definite integral *we have to adjust the limits of integration properly*:

$$(28) \quad \int_a^b f[g(u)] \frac{dg}{du} du = \int_{g(a)}^{g(b)} f(x) dx$$

because if $u = a$ or $u = b$ then $x = g(a)$ or $x = g(b)$ respectively. This also follows from the observation:

$$\begin{aligned} \int_{g(a)}^{g(b)} f(x) dx &= F(g(b)) - F(g(a)) \\ &= \int_a^b f[g(u)] \frac{dg}{du} du. \end{aligned}$$

Example 2.1. To see that the proper limits of integration *do* make the difference we

evaluate the simple integral $\int_0^2 (2u - 1) du$. Using the substitution $x = 2u - 1$, $du = \frac{1}{2} dx$ and new limits $-1 = 2 \cdot 0 - 1$ and $3 = 2 \cdot 2 - 1$ we get:

$$(29) \quad \int_0^2 (2u - 1) du = \int_{-1}^3 \frac{x}{2} dx = \left[\frac{x^2}{4} \right]_{-1}^3 = \frac{9}{4} - \frac{1}{4} = 2.$$

Note that if the limits is not changed we will get a wrong answer 1. To verify the above solution we make it plainly as well:

$$(30) \quad \int_0^2 (2u - 1) du = [u^2 - u]_0^2 = (2^2 - 2) - (0^2 - 0) = 2.$$

Finally the answer can be checked by consideration the area of the two triangles formed by the graph of function $y = 2x - 1$ and the horizontal axis.

Example 2.2. Let us demonstrate relation (18) using the change of variable $g(u) = u/k$ in the function $f(x) = 1/x$:

$$\int_{ka}^{kb} \frac{1}{u} du = \int_{ka}^{kb} \frac{1}{u/k} \frac{1}{k} du = \int_a^b \frac{1}{x} dx.$$

Example 2.3. We can use this to integrate $\sin(ax)$ and $\cos(ax)$ without having to guess as we did in sections 2.4.1 and 2.4.2. For example, for

$$\int \sin(ax) dx$$

put $u = ax$. Then $\frac{du}{dx} = a$ and $dx = du/a$, so we get

$$\int \sin(ax) dx = \int \sin(u) \frac{du}{a} = -\frac{1}{a} \cos(u) = -\frac{1}{a} \cos(ax),$$

This is the same as (15).

Example 2.4 (Another example of substitution). For $\int x^5 e^{x^6} dx$, put $u = x^6$ and then

$$\frac{du}{dx} = 6x^5, \text{ so } dx = \frac{du}{6x^5}.$$

We get

$$\int x^5 e^u \frac{du}{6x^5} = \frac{1}{6} \int e^u du = \frac{1}{6} e^u + C = \frac{1}{6} e^{x^6} + C.$$

2.1.1. *Tangent*. We can use change of variable to find $\int \tan x dx = \int \frac{\sin x}{\cos x} dx$.

Put $u = \cos x$. Differentiating gives $\frac{du}{dx} = -\sin x$, or $dx = -du/\sin x$.

We then have

$$\begin{aligned} \int \tan x dx &= \int \frac{\sin x}{\cos x} dx = \int -\frac{\sin x}{u} \frac{du}{\sin x} \\ (31) \qquad &= \int -\frac{du}{u} = -\ln|u| + C = -\ln|\cos x| + C, \end{aligned}$$

from (24). It is worth differentiating $\tan x$ just to see what we get. We have

$$\frac{d}{dx} \tan x = \frac{d}{dx} \frac{\sin x}{\cos x} = \frac{(\cos x)(\cos x) - (\sin x)(-\sin x)}{\cos^2 x} = \frac{1}{\cos^2 x} = \sec^2 x.$$

So we also have

$$(32) \qquad \int \sec^2 x dx = \tan x + C.$$

2.1.2. *Cotangent*. Have $\int \cot x dx = \int \frac{\cos x}{\sin x} dx$.

Put $u = \sin x$. Differentiating gives $du = \cos x dx$, or $dx = du/\cos x$.

We then have

$$(33) \qquad \int \cot x dx = \int \frac{\cos x}{\sin x} dx = \int \frac{\cos x}{u} \frac{du}{\cos x} = \int \frac{du}{u} = \ln|u| + C = \ln|\sin x| + C,$$

from (24). Again, it is worth differentiating $\cot x$ just to see what we get. We have

$$\frac{d}{dx} \cot x = \frac{d}{dx} \frac{\cos x}{\sin x} = \frac{(\sin x)(-\sin x) - (\cos x)(\cos x)}{\sin^2 x} = -\frac{1}{\sin^2 x} = -\operatorname{cosec}^2 x.$$

So we have

$$(34) \qquad \int \operatorname{cosec}^2 x dx = -\cot x + C.$$

2.1.3. *Derivative of a function divided by the function.* The integral of the tangent and cotangent is an example of a general class of integrals of the form

$$\int \frac{1}{f(x)} \frac{df}{dx} dx, \quad \text{where } f(x) \text{ is some function of } x.$$

If we make the substitution $u = f(x)$, then $du = \frac{df}{dx} dx$ and the integral becomes

$$(35) \quad \int \frac{1}{f(x)} \frac{df}{dx} dx = \int \frac{du}{u} = \ln|u| + C = \ln|f(x)| + C,$$

from equation (24).

Example 2.5. (1) For example, with $f(x) = x^2 + 4$ and $f'(x) = \frac{df}{dx} = 2x$, we see that

$$\int \frac{2x}{x^2 + 4} dx = \ln(x^2 + 4) + C.$$

(2) We know that $\int 1 dx = x + C$, but let us make a twist using (35) for $u = e^x$:

$$\int 1 dx = \int \frac{e^x}{e^x} dx = \int \frac{1}{u} du = \ln(e^x) + C$$

that is $\ln(e^x) = x$ comparing values of both sides for $x = 0$. In this fancy way we see once more that the exponent and logarithm are inverse functions.

Question: why did we write above logarithms omitting absolute values of their arguments?

2.2. Other Trigonometric Integrals.

(1) $\int \sin^2 x dx$. Since $\cos 2x = 1 - 2\sin^2 x$, we may use the formula

$$\sin^2 x = \frac{1}{2}[1 - \cos(2x)].$$

Then

$$(36) \quad \int \sin^2 x dx = \int \frac{1}{2}[1 - \cos(2x)] dx = \frac{x}{2} - \frac{1}{4} \sin(2x) + C.$$

(2) $\int \cos^2 x dx$. Since $\cos 2x = 2\cos^2 x - 1$, we may use the formula

$$\cos^2 x = \frac{1}{2}[1 + \cos(2x)].$$

Then

$$(37) \quad \int \cos^2 x dx = \int \frac{1}{2}[1 + \cos(2x)] dx = \frac{x}{2} + \frac{1}{4} \sin(2x) + C.$$

(3) $\int \sin(ax) \cos(bx) dx$. We have

$$\sin(ax + bx) = \sin(ax) \cos(bx) + \cos(ax) \sin(bx)$$

and

$$\sin(ax - bx) = \sin(ax) \cos(bx) - \cos(ax) \sin(bx).$$

Adding gives

$$(38) \quad \sin(ax) \cos(bx) = \frac{1}{2}[\sin(ax + bx) + \sin(ax - bx)].$$

Then

$$(39) \quad \begin{aligned} \int \sin(ax) \cos(bx) dx &= \int \frac{1}{2}[\sin(ax + bx) + \sin(ax - bx)] dx \\ &= -\frac{1}{2(a+b)} \cos(ax + bx) - \frac{1}{2(a-b)} \cos(ax - bx) + C. \end{aligned}$$

2.3. Integration by Parts. Consider the product rule for the differentiation of a product of two functions

$$(40) \quad \frac{d}{dx} f(x)g(x) = g \frac{df}{dx} + f \frac{dg}{dx}.$$

Integrating both sides gives

$$f(x)g(x) = \int g(x) \frac{df}{dx} dx + \int f(x) \frac{dg}{dx} dx.$$

i.e.,

$$(41) \quad \int f(x) \frac{dg}{dx} dx = f(x)g(x) - \int g(x) \frac{df}{dx} dx.$$

This formula is known as *integration by parts*.

For the definite integral integration by parts is:

$$(42) \quad \int_a^b f(x) \frac{dg}{dx} dx = [f(x)g(x)]_a^b - \int_a^b g(x) \frac{df}{dx} dx.$$

We note that integration by parts does not completely solve problem of integration, instead it expresses one integral $\int f(x) \frac{dg}{dx} dx$ through another $\int g(x) \frac{df}{dx} dx$. For this procedure to be possible and useful two conditions need to be observed:

- (1) We shall be able to integrate the function which we treat as $\frac{dg}{dx}$. (This explains the name: we integrate only a part of the product $f(x) \frac{dg}{dx}$).
- (2) The “new” integral $\int g(x) \frac{df}{dx} dx$ shall be easier to find than the “old” one $\int f(x) \frac{dg}{dx} dx$.

Various situations of such facilitation are illustrated by the following example.

Example 2.6. (1) $\int xe^x dx$. Let $f(x) = x$, $\frac{dg}{dx} = e^x$. Then $g = e^x$, $\frac{df}{dx} = 1$ and (41) gives

$$\int xe^x dx = xe^x - \int e^x dx = xe^x - e^x + C.$$

(2) $\int \ln x dx$ (for $x > 0$). Let $f(x) = \ln x$, $\frac{dg}{dx} = 1$. Then $g = x$, $\frac{df}{dx} = \frac{1}{x}$ and (41) gives

$$\int \ln x dx = x \ln x - \int x \frac{1}{x} dx = x \ln x - x + C.$$

For example

$$\int_1^e \ln x \, dx = [x \ln x - x]_1^e = (e - e) - (0 - 1) = 1,$$

since $\ln e = 1$ and $\ln 1 = 0$.

- (3) $\int x \sin x \, dx$. This and the next cases are similar to the example 1. Let $f(x) = x$, $\frac{dg}{dx} = \sin x$. Then $g = -\cos x$, $\frac{df}{dx} = 1$ and (41) gives

$$\int x \sin x \, dx = -x \cos x + \int \cos x \, dx = -x \cos x + \sin x + C.$$

- (4) $\int x \cos x \, dx$. Let $f(x) = x$, $\frac{dg}{dx} = \cos x$. Then $g = \sin x$, $\frac{df}{dx} = 1$ and (41) gives

$$\int x \cos x \, dx = x \sin x - \int \sin x \, dx = x \sin x + \cos x + C.$$

- (5) For $\int x^2 e^x \, dx$ we may take $f(x) = x^2$ and $g'(x) = e^x$. Thus we take $g(x) = e^x$, and (41) gives

$$\int x^2 e^x \, dx = x^2 e^x - \int 2x e^x \, dx,$$

and we can use the result of example (1) to do the last integral. Effectively, we have integrated by parts twice, at each stage making the integrand (the function we have to integrate) simpler.

- (6) $\int \sin x e^x \, dx$. Let $f(x) = \sin x$, $\frac{dg}{dx} = e^x$. Then $g = e^x$, $\frac{df}{dx} = \cos x$ and (41) gives

$$I = \int \sin x e^x \, dx = \sin x e^x - \int \cos x e^x \, dx.$$

Let us integrate the second term by parts. Put $f(x) = \cos x$, $\frac{dg}{dx} = e^x$. Then $g = e^x$, $\frac{df}{dx} = -\sin x$ and (41) gives

$$\int \cos x e^x \, dx = \cos x e^x + \int \sin x e^x \, dx.$$

So we get

$$I = \sin x e^x - \cos x e^x - \int \sin x e^x \, dx = \sin x e^x - \cos x e^x - I.$$

So

$$I = \int \sin x e^x \, dx = \frac{1}{2} e^x (\sin x - \cos x) + C.$$

The same trick gives us $\int \cos x e^x \, dx$.

Remark 2.7. Summing up: by its nature, integration by parts does not solve an integration question: instead it replaces one integral by another. Hopefully, this would be a step towards a solution! But the last two examples show that *you may need more than just one step* before you will reach your target.

2.3.1. *Change of variable vs. integration by parts.* Let us compare the formula (27) for change of variable and (41) of integration by parts re-written more uniformly:

$$\int f(g(x)) \frac{dg(x)}{dx} dx = \int f(t) dt, \quad \text{where } t = g(x);$$

$$\int f(x) \frac{dg(x)}{dx} dx = f(x)g(x) - \int g(x) \frac{df(x)}{dx} dx.$$

We note, that the both method has the *common starting point*: a factor in the integral need to be identified as the derivative $\frac{dg(x)}{dx}$ of a function $g(x)$. The *required condition* in both cases is: we need to be able to integrate $\frac{dg(x)}{dx}$ to obtain $g(x)$.

However, two methods has the *different mechanism* to approach a solution. We change the variable from $f(g(x))$ to $f(t)$ if we expect that $f(t)$ can be integrated. In integration by part, we look for the product $g(x) \frac{df(x)}{dx}$ to be more suitable for integration than $f(x) \frac{dg(x)}{dx}$.

Yet, there are examples, where the both methods are efficient.

Example 2.8. We already discussed how to evaluate $\int \cos x \cdot \sin x dx$ using trigonometric formulae in § 2.2(3) in slightly more general form. Now we will do it differently.

(1) We make the change of variable $g(x) = \cos x$, then $\frac{dg(x)}{dx} = -\sin x$. Thus, for $t = g(x) = \cos x$ we have:

$$\int \cos x \cdot \sin x dx = - \int \cos x \frac{d \cos x}{dx} dx = - \int t dt = -\frac{1}{2}t^2 + C = -\frac{1}{2} \cos^2 x + C.$$

(2) Integrating by parts we again put $\frac{dg(x)}{dx} = \sin x$ and $f(x) = \cos x$. Then $g(x) = -\cos x$ and $\frac{df(x)}{dx} = -\sin x$ and we obtain:

$$(43) \quad \int \cos x \cdot \sin x dx = -\cos^2 x - \int \cos x \cdot \sin x dx.$$

Now we in a position similar to Example 2.6(6): put $I = \int \cos x \cdot \sin x dx$, then equation (43) means $I = -\cos^2 x - I$ or $2I = -\cos^2 x$. Thus again we obtained:

$$\int \cos x \cdot \sin x dx = -\frac{1}{2} \cos^2 x + C.$$

Note, that $\int \cos x \cdot \sin x dx = \frac{1}{2} \sin^2 x + C$ is a correct answer as well, since $-\frac{1}{2} \cos^2 x$ and $\frac{1}{2} \sin^2 x$ are different by a constant only (Pythagoras theorem!)

See also further Example 6.3.

2.4. Rational functions and partial fractions. There is a large class of functions which can be integrated in a routine fashion, we are discussing it in this section. Recall, that a multiple of a power function, say $3x^4$, is called *minomial*. A sum of monomials (all with integer powers), say $7x^4 + 5x^3 + 6x$, is called *polynomial*. The *degree* of a polynomial is the

maximal degree of a constituting monomials. For the previous example of polynomial degree is 4.

Definition 2.9. A *rational function* is a function of the form

$$f(x) = \frac{p(x)}{q(x)}$$

where $p(x)$ and $q(x)$ are polynomials in x with $q(x) \neq 0$.

For example

$$\frac{x+3}{x-7}, \quad \frac{x-2}{2x^3+x^2-x}, \quad \frac{x^2+3x+2}{1}.$$

The last is the same as x^2+3x+2 , so any polynomial is also a rational function.

Definition 2.10. A *proper* rational function is one in which the degree of the numerator is less than the degree of the denominator. Otherwise it is called *improper*.

Remark 2.11. Any rational function can be written as the *sum* of a polynomial and a proper rational function.

For example

$$\frac{x^3+x^2+2}{x^2-4} = x + \frac{x^3+x^2+2-x(x^2-4)}{x^2-4} = x + \frac{x^2+4x+2}{x^2-4},$$

where we got the x by dividing the highest-degree term on top, x^3 , by the highest-degree term below, x^2 . We continue:

$$x + \frac{x^2+4x+2}{x^2-4} = x + 1 + \frac{x^2+4x+2-1(x^2-4)}{x^2-4} = x + 1 + \frac{4x+6}{x^2-4},$$

where we got the 1 by dividing the highest-degree term on top, x^2 , by the highest-degree term below, x^2 .

Recall that if you divide a polynomial by a divisor (this can be done by long division if you know it), then

$$\text{polynomial} = \text{divisor} \cdot \text{quotient} + \text{remainder}$$

Therefore

$$\frac{\text{polynomial}}{\text{divisor}} = \text{quotient} + \frac{\text{remainder}}{\text{divisor}}.$$

In our case, $x^3+x^2+2 = (x^2-4)(x+1) + (4x+6)$, which gives us the same answer.

The equality

$$\frac{3x+4}{(x+1)(x+2)} = \frac{1}{x+1} + \frac{2}{x+2}$$

expresses a complicated rational function as a sum of simple ones, a *partial fraction*. This is a key observation for the following method of integration proposed by [Ostrogradsky](#)¹.

¹Ostrogradsky was a dedicated and successful lecturer. In particular, he said: "A better learning is not limited to memorising, it develops skills to use the learned material for problem solving".

Example 2.12. Consider

$$\frac{3x - 1}{(x + 1)(x - 3)}.$$

We try to write it as

$$\frac{3x - 1}{(x + 1)(x - 3)} = \frac{A}{x + 1} + \frac{B}{x - 3}$$

where A and B are constants. Multiplying both sides by $(x + 1)(x - 3)$ gives

$$(44) \quad 3x - 1 = A(x - 3) + B(x + 1).$$

This is an identity which is true for all x .

Putting $x = 3$, it gives $8 = 4B$, so $B = 2$.

Putting $x = -1$, it gives $-4 = -4A$, so $A = 1$.

With these values of A and B the identity does hold, for

$$3x - 1 = (x - 3) + 2(x + 1).$$

Therefore

$$\frac{3x - 1}{(x + 1)(x - 3)} = \frac{1}{x + 1} + \frac{2}{x - 3}.$$

Alternatively, find A and B as follows:

Coefficient of x in (44): $3 = A + B$.

Constant term in (44): $-1 = -3A + B$.

Now solve for A and B , to get $A = 1$ and $B = 2$ again.

Now, we can do an integral:

$$\begin{aligned} \int_0^2 \frac{3x - 1}{(x + 1)(x - 3)} dx &= \int_0^2 \left(\frac{1}{x + 1} + \frac{2}{x - 3} \right) dx = [\ln|x + 1| + 2 \ln|x - 3|]_0^2 \\ &= (\ln 3 + 2 \ln 1) - (\ln 1 + 2 \ln 3) = -\ln 3, \end{aligned}$$

since $\ln 1 = 0$.

This method only works for proper rational functions. In general, first write the rational function as the sum of a polynomial and a proper rational function, and then convert that to partial fractions using the method above.

Example 2.13. Write $\frac{x^3}{(x + 1)(x + 2)}$ in partial fractions.

This is not a proper rational function. Note that $(x + 1)(x + 2) = x^2 + 3x + 2$.

We have

$$\begin{aligned} \frac{x^3}{x^2 + 3x + 2} &= x + \frac{x^3 - x(x^2 + 3x + 2)}{x^2 + 3x + 2} = x + \frac{-3x^2 - 2x}{x^2 + 3x + 2} \\ &= x - 3 + \frac{-3x^2 - 2x - (-3(x^2 + 3x + 2))}{x^2 + 3x + 2} = x - 3 + \frac{7x + 6}{x^2 + 3x + 2}. \end{aligned}$$

Alternatively, we may divide x^3 by $x^2 + 3x + 2$. It gives quotient $x - 3$ and remainder $7x + 6$.

Therefore

$$\frac{x^3}{(x+1)(x+2)} = x - 3 + \frac{7x+6}{(x+1)(x+2)}.$$

Now using the usual method,

$$\frac{7x+6}{(x+1)(x+2)} = \frac{A}{x+1} + \frac{B}{x+2}.$$

Therefore

$$(45) \quad 7x+6 = A(x+2) + B(x+1).$$

Putting $x = -2$ gives $-8 = -B$, so $B = 8$.

Putting $x = -1$ gives $-1 = A$.

Alternatively, the coefficient of x in (45) is $7 = A + B$. The constant term is $6 = 2A + B$. Again $A = -1$ and $B = 8$.

Therefore

$$\frac{7x+6}{(x+1)(x+2)} = -\frac{1}{x+1} + \frac{8}{x+2}$$

so

$$\frac{x^3}{(x+1)(x+2)} = x - 3 - \frac{1}{x+1} + \frac{8}{x+2}.$$

2.4.1. Quadratic factors. Recall, that for a *quadratic polynomial* of the form $ax^2 + bx + c$, where $a \neq 0$, its *discriminant* is $D = b^2 - 4ac$. Using **completing the square** method we can show that the quadratic polynomial has two distinct (real) roots if and only if $D > 0$.

If one of the factors is quadratic and cannot be factorised (that is, its discriminant is negative), then one has to allow the corresponding numerator to be linear (i.e., of degree 1).

Example 2.14. Write $\frac{5x+7}{(x-1)(x^2+x+2)}$ in partial fractions.

Assume

$$\frac{5x+7}{(x-1)(x^2+x+2)} = \frac{A}{x-1} + \frac{Bx+C}{x^2+x+2}.$$

Multiply both sides by the denominator.

$$5x+7 = A(x^2+x+2) + (Bx+C)(x-1).$$

Putting $x = 1$ gives $12 = 4A$, so $A = 3$. Therefore

$$5x+7 = 3(x^2+x+2) + (Bx+C)(x-1).$$

Since this is true for all x , we can compare coefficients. Therefore

$$\begin{aligned} \text{coefficient of } x^2 : 0 &= 3 + B \\ \text{constant term} : 7 &= 6 - C \end{aligned}$$

Therefore $B = -3$ and $C = -1$, and

$$(46) \quad \frac{5x+7}{(x-1)(x^2+x+2)} = \frac{3}{x-1} - \frac{3x+1}{x^2+x+2}.$$

Can we integrate these functions? It turns out that we still need to learn some theory, see Example 2.24.

Example 2.15. $\int \frac{x^3 + x}{x^2 - x - 6} dx$.

This is not proper, since the top has degree one more than the bottom, so we must write

$$(47) \quad x^3 + x = (ax + b)(x^2 - x - 6) + (cx + d),$$

where a, b, c, d are constants. Equivalently,

$$\frac{x^3 + x}{x^2 - x - 6} = ax + b + \frac{cx + d}{x^2 - x - 6}.$$

This can be done by long division (if you know it), or by the method we did earlier, or simply by equating coefficients in (47).

Coefficient of x^3 : $1 = a$.

Coefficient of x^2 : $0 = b - a$, so $b = 1$.

Coefficient of x : $1 = -6a - b + c$, so $c = 8$.

Coefficient of 1 (constant term): $0 = -6b + d$, so $d = 6$.

Hence $\frac{x^3 + x}{x^2 - x - 6} = x + 1 + \frac{8x + 6}{x^2 - x - 6}$. But $x^2 - x - 6 = (x + 2)(x - 3)$.

So we can write

$$\frac{8x + 6}{x^2 - x - 6} = \frac{A_1}{x + 2} + \frac{A_2}{x - 3}.$$

This gives $8x + 6 = A_1(x - 3) + A_2(x + 2)$.

Put $x = -2$ to get $-10 = -5A_1$. Put $x = 3$ to get $30 = 5A_2$.

Solving these gives $A_1 = 2$, $A_2 = 6$. So we finally have

$$\int \frac{x^3 + x}{x^2 - x - 6} dx = \int \left[x + 1 + \frac{2}{x + 2} + \frac{6}{x - 3} \right] dx = \frac{x^2}{2} + x + 2 \ln|x + 2| + 6 \ln|x - 3| + C,$$

from equations (13) and (23).

2.4.2. Repeated factors. So far each factor has occurred just once. If the denominator includes a factor like $(x - a)^2$, we include partial fractions of the form

$$\frac{A}{x - a} + \frac{B}{(x - a)^2}.$$

Example 2.16. Write $\frac{3x + 5}{(x - 2)^2}$ in partial fractions.

Write

$$\frac{3x + 5}{(x - 2)^2} = \frac{A}{x - 2} + \frac{B}{(x - 2)^2}.$$

As usual, multiply by the denominator to get

$$3x + 5 = A(x - 2) + B.$$

Comparing coefficients gives $A = 3$ and $B = 11$, and so

$$\frac{3x + 5}{(x - 2)^2} = \frac{3}{x - 2} + \frac{11}{(x - 2)^2}.$$

Hence

$$\int \frac{3x + 5}{(x - 2)^2} dx = \int \left[\frac{3}{x - 2} + \frac{11}{(x - 2)^2} \right] dx = 3 \ln|x - 2| - \frac{11}{x - 2} + C.$$

Example 2.17. Write $\frac{x^2 - 17x - 8}{(x - 3)(x + 2)^2}$ in partial fractions.

Write

$$\frac{x^2 - 17x - 8}{(x - 3)(x + 2)^2} = \frac{A}{x - 3} + \frac{B}{x + 2} + \frac{C}{(x + 2)^2}.$$

Multiply by the denominator to get

$$\begin{aligned} x^2 - 17x - 8 &= A(x + 2)^2 + B(x - 3)(x + 2) + C(x - 3) \\ &= A(x^2 + 4x + 4) + B(x^2 - x + 6) + C(x - 3). \end{aligned}$$

Put $x = 3$ to get $9 - 17 \times 3 - 8 = 25A$, so $A = -2$.

Put $x = -2$ to get $4 + 17 \times 2 - 8 = -5C$, so $C = -6$.

Compare coefficients of x^2 to get $1 = A + B$, so $B = 3$.

Therefore

$$\frac{x^2 - 17x - 8}{(x - 3)(x + 2)^2} = -\frac{2}{x - 3} + \frac{3}{x + 2} - \frac{6}{(x + 2)^2}.$$

Example 2.18. Write as partial fractions:

$$\frac{3 + 2x - x^2}{(x - 1)(2x^2 + x + 1)}.$$

We need to write

$$\frac{3 + 2x - x^2}{(x - 1)(2x^2 + x + 1)} = \frac{A}{x - 1} + \frac{Bx + C}{2x^2 + x + 1},$$

and find the constants A , B and C . So we multiply by $(x - 1)(2x^2 + x + 1)$ to get

$$3 + 2x - x^2 = A(2x^2 + x + 1) + (Bx + C)(x - 1).$$

Take $x = 1$ so that $3 + 2 - 1 = A(2 + 1 + 1)$, or $A = 1$.

Look at the coefficient of x^2 , so $-1 = 2A + B$, and $B = -3$.

Look at the constant term, so $3 = A - C$, and $C = -2$.

Hence

$$\frac{3 + 2x - x^2}{(x - 1)(2x^2 + x + 1)} = \frac{1}{x - 1} - \frac{3x + 2}{2x^2 + x + 1}.$$

2.4.3. *Summary of Ostrogradsky's method.* To find $\int \frac{p(x)}{q(x)} dx$ perform the following steps:

- (1) If the fraction is proper (that is the order of numerator $p(x)$ is smaller than the order of denominator $q(x)$) proceed to the next step letting $r(x) = p(x)$ and $p_1(x) = 0$. Otherwise, perform polynomial long-division to find the quotient $p_1(x)$ and remainder $r(x)$:

$$\frac{p(x)}{q(x)} = p_1(x) + \frac{r(x)}{q(x)}.$$

- (2) Factor the denominator $q(x)$ into irreducible polynomials: linear and irreducible quadratic polynomials:

$$q(x) = (x - a)^\alpha \cdots (x - b)^\beta (x^2 + px + q)^\mu \cdots (x^2 + rx + s)^\nu.$$

(3) Find the partial fraction decomposition:

$$\begin{aligned} \frac{r(x)}{q(x)} &= \frac{A}{(x-a)^\alpha} + \frac{A_1}{(x-a)^{\alpha-1}} + \dots + \frac{A_{\alpha-1}}{x-a} + \dots \\ &+ \frac{B}{(x-b)^\beta} + \frac{B_1}{(x-b)^{\beta-1}} + \dots + \frac{B_{\beta-1}}{x-b} \\ &+ \frac{Kx+L}{(x^2+px+q)^\mu} + \frac{K_1x+L_1}{(x^2+px+q)^{\mu-1}} + \dots + \frac{K_{\mu-1}x+L_{\mu-1}}{x^2+px+q} + \dots \\ &+ \frac{Mx+N}{(x^2+rx+s)^\nu} + \frac{M_1x+N_1}{(x^2+rx+s)^{\nu-1}} + \dots + \frac{M_{\nu-1}x+N_{\nu-1}}{x^2+rx+s}. \end{aligned}$$

(4) Integrate the polynomial $p_1(x)$ and rational function $\frac{r(x)}{q(x)}$ as was decomposed in the previous step.

Remark 2.19. We do not consider integration of repeated quadratic factors of the denominator in this course. If you are curious, watch a sample of such integration from [this video](#) or read a more formal [description of Ostrogradski's method](#).

2.5. Trigonometric t Substitution. One calculus textbook (Spivak) describes this as “undoubtedly the world’s sneakiest substitution”! It was invented by [Weierstrass](#). The substitution allows to reduce an integral from trigonometric functions to an integral from rational functions, the later can be calculated by the Ostrogradsky’s method, see subsection [2.4.3](#).

Put $t = \tan(x/2)$. Then

$$(48) \quad \tan x = \frac{2 \tan(x/2)}{1 - \tan^2(x/2)} = \frac{2t}{1 - t^2},$$

Also:

$$\begin{aligned} \sin x &= 2 \sin(x/2) \cos(x/2) \\ &= 2 \frac{\sin(x/2)}{\cos(x/2)} \cos^2(x/2) \\ &= 2 \tan(x/2) \frac{1}{1 + \tan^2(x/2)} \\ (49) \quad &= \frac{2t}{1 + t^2} \end{aligned}$$

Finally:

$$(50) \quad \cos x = \frac{\sin x}{\tan x} = \frac{1 - t^2}{1 + t^2}.$$

Differentiating $t = \tan(x/2)$ gives

$$(51) \quad \frac{dt}{dx} = \frac{1}{2} \sec^2(x/2) = \frac{1}{2} (1 + \tan^2(x/2)) = \frac{1}{2} (1 + t^2), \quad \text{so} \quad dx = \frac{2dt}{1 + t^2}.$$

Example 2.20. $\int \frac{dx}{\sin x}$, for x such that $\sin x > 0$. Put $t = \tan(x/2)$ to get

$$\int \frac{1+t^2}{2t} \frac{2dt}{1+t^2} = \int \frac{dt}{t} = \ln(t) + C = \ln[\tan(x/2)] + C.$$

This can also be used for $\int \frac{dx}{\cos x}$, etc.

Example 2.21. Let us consider once more the integral $\int \cos x \cdot \sin x \, dx$, which was already solved by three different methods in § 2.2(3) and Example 2.8. Using the trigonometric substitution we obtain:

$$\int \cos x \cdot \sin x \, dx = \int \frac{1-t^2}{1+t^2} \frac{2t}{1+t^2} \frac{2 \, dt}{1+t^2} = \int \frac{4t(1-t^2)}{(1+t^2)^3} \, dt.$$

Although, the last integral is still doable through the partial fraction decomposition (using repeated factors), this approach would be the least efficient among all considered so far.

Remark 2.22. Note that $\operatorname{cosec} x + \cot x = \frac{1+t^2}{2t} + \frac{1-t^2}{2t} = \frac{1}{t}$, so we can express functions of t in terms of trigonometric functions of x rather than $x/2$ if we wish.

2.6. Inverse Trigonometric Functions. To complete Ostrogradsky's method we will need to integrate irreducible quadratic fractions, for example $\int \frac{1}{x^2+1} \, dx$. Surprisingly, to this end we need to study inverse trigonometric functions. See the previous discussion of inverse functions producing logarithm in subsection 1.6.

Definition 2.23. Define the *inverse trigonometric functions* in the standard way i.e.

$$(52) \quad \begin{aligned} y &= \sin^{-1}(x) \Rightarrow x = \sin(y) & \text{a)} \\ y &= \cos^{-1}(x) \Rightarrow x = \cos(y) & \text{b)} \\ y &= \tan^{-1}(x) \Rightarrow x = \tan(y) & \text{c)} \end{aligned}$$

However, we have to restrict the domain, and decide which range of values to take. As shown on Fig. 7, the inverse functions are well-defined if

$$(53) \quad \begin{array}{lll} \sin^{-1}(x) & \text{Domain} & -1 \leq x \leq 1, \quad \text{Range} \quad -\pi/2 \leq y \leq \pi/2 \quad \text{a)}, \\ \cos^{-1}(x) & \text{Domain} & -1 \leq x \leq 1, \quad \text{Range} \quad 0 \leq y \leq \pi \quad \text{b)}, \\ \tan^{-1}(x) & \text{Domain} & -\infty \leq x \leq \infty, \quad \text{Range} \quad -\pi/2 \leq y \leq \pi/2 \quad \text{c)}. \end{array}$$

We can use the chain rule to determine the derivatives in the same way as for $\ln(x)$. If

$$y = \sin^{-1}(x), \quad \text{then} \quad x = \sin(y),$$

Differentiate to get

$$1 = \cos(y) \frac{dy}{dx}, \quad \text{so} \quad \frac{dy}{dx} = \frac{1}{\cos(y)}.$$

Using $\sin^2 y + \cos^2 y = 1$ we get

$$(54) \quad \frac{d}{dx} \sin^{-1}(x) = \frac{1}{\cos(y)} = \frac{1}{\sqrt{1-\sin^2(y)}} = \frac{1}{\sqrt{1-x^2}}.$$

Similarly

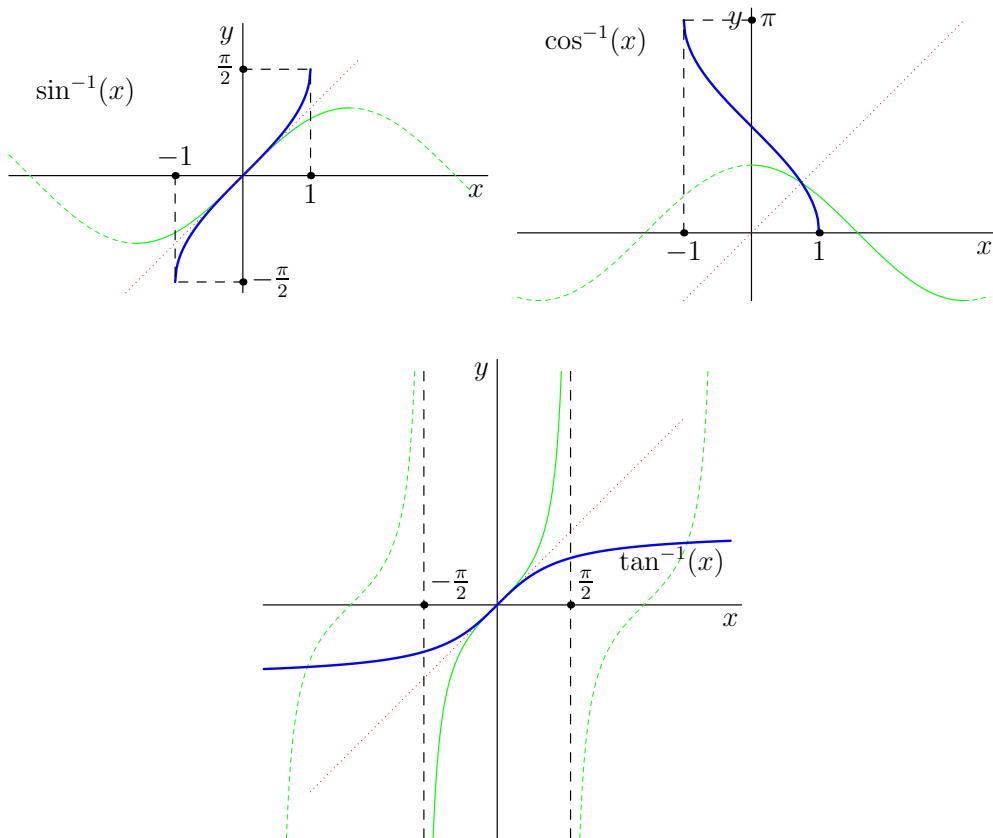

FIGURE 7. Inverse trigonometric functions are drawn in blue. Their graphs are mirror reflections in the red dotted line of the part of trigonometric function green graph.

$$(55) \quad \frac{d}{dx} \cos^{-1}(x) = \frac{-1}{\sqrt{1-x^2}},$$

$$(56) \quad \frac{d}{dx} \tan^{-1}(x) = \frac{1}{1+x^2}.$$

So

$$\int \frac{dx}{\sqrt{1-x^2}} = \sin^{-1}(x) + C \quad \text{and} \quad \int \frac{dx}{1+x^2} = \tan^{-1}(x) + C.$$

We won't normally use $\cos^{-1}(x)$ as it gives us nothing new. This works for definite integrals too, so

$$\int_0^1 \frac{dx}{\sqrt{1-x^2}} = [\sin^{-1}(x)]_0^1 = \frac{\pi}{2} - 0 = \frac{\pi}{2}.$$

The above formulae tell us how to do certain types of integrals.

Example 2.24. (1) $\int \frac{dx}{\sqrt{a^2 - x^2}}$. Put $x = a \sin \theta$. Then $dx = a \cos \theta d\theta$. We get

$$\int \frac{dx}{\sqrt{a^2 - x^2}} = \int \frac{a \cos \theta}{\sqrt{a^2 - a^2 \sin^2 \theta}} d\theta = \int d\theta = \theta + C = \sin^{-1}(x/a) + C.$$

(2) $\int \frac{dx}{\sqrt{8 - 2x - x^2}}$. Since $x^2 + 2x - 8 = (x + 1)^2 - 9$, this is just $\int \frac{dx}{\sqrt{9 - (x + 1)^2}}$. So put $u = x + 1$ and $du = dx$, so we get

$$\int \frac{du}{\sqrt{9 - u^2}} = \sin^{-1}(u/3) + C = \sin^{-1}\left(\frac{x+1}{3}\right) + C.$$

(3) $\int \frac{dx}{x^2 + a^2}$. Put $x = a \tan \theta$. Then $dx = a \sec^2 \theta d\theta$. We get

$$\int \frac{dx}{x^2 + a^2} = \int \frac{a \sec^2 \theta}{a^2 \tan^2 \theta + a^2} d\theta = \int \frac{d\theta}{a} = \frac{\theta}{a} + C = \frac{1}{a} \tan^{-1}(x/a) + C,$$

since $\sec^2 \theta = 1 + \tan^2 \theta$.

(4) $\int \frac{dx}{x^2 - 4x + 20}$. We can write $x^2 - 4x + 20 = (x - 2)^2 + 16$. Put $x - 2 = 4 \tan \theta$. Then $dx = 4 \sec^2 \theta d\theta$.

We get

$$\begin{aligned} \int \frac{dx}{x^2 - 4x + 20} &= \int \frac{4 \sec^2 \theta}{16 \tan^2 \theta + 16} d\theta = \int \frac{d\theta}{4} = \frac{\theta}{4} + C \\ &= \frac{1}{4} \tan^{-1}[(x - 2)/4] + C \end{aligned}$$

For example,

$$\int_{-2}^2 \frac{dx}{x^2 - 4x + 20} = \frac{1}{4} \left[\tan^{-1} \frac{x - 2}{4} \right]_{-2}^2 = \frac{1}{4} (0 - (-\pi/4)) = \frac{\pi}{16}.$$

(5) $\int \frac{2x + 3}{x^2 - 2x + 5} dx$. Here we need a combination of techniques from Example 2.5 and the above 2.24(4):

$$\begin{aligned} \int \frac{2x + 3}{x^2 - 2x + 5} dx &= \int \frac{(2x - 2) + (2 + 3)}{x^2 - 2x + 5} dx \\ (57) \qquad \qquad \qquad &= \int \frac{2x - 2}{x^2 - 2x + 5} dx + \int \frac{5}{x^2 - 2x + 5} dx. \end{aligned}$$

For the first integral (57) we make the substitution $u = x^2 - 2x + 5$ with $du = (2x - 2)dx$:

$$(58) \qquad \int \frac{2x - 2}{x^2 - 2x + 5} dx = \int \frac{du}{u} = \ln|u| + C = \ln|x^2 - 2x + 5| + C.$$

For the second integral (57) we complete the square $x^2 - 2x + 5 = (x - 1)^2 + 4$ and make the substitution $x - 1 = 2 \tan t$ with $dx = \frac{2dt}{\cos^2 t}$:

$$(59) \quad \int \frac{5}{x^2 - 2x + 5} dx = 5 \int \frac{2 dt}{\cos^2 t (4 \tan^2 t + 4)} = \frac{5}{2} \int dt = \frac{5}{2} t + C \\ = \frac{5}{2} \tan^{-1} \left(\frac{x-1}{2} \right) + C.$$

Combining two integrals (58) and (59) together we obtain the answer:

$$\int \frac{2x + 3}{x^2 - 2x + 5} dx = \ln |x^2 - 2x + 5| + \frac{5}{2} \tan^{-1} \left(\frac{x-1}{2} \right) + C.$$

(6) Integrate (46).

We can see that we cannot use partial fractions for examples 2.24(3) and 2.24(4) because $x^2 + a^2$ and $x^2 - 4x + 20$ cannot be factorised (at least not with real numbers).

3. HYPERBOLIC FUNCTIONS

We have seen that the integral $\int \frac{1}{\sqrt{1-x^2}} dx$ is solved by the inverse sine function. Integration of an apparently similar function $\int \frac{1}{\sqrt{1+x^2}} dx$ requires introduction of new hyperbolic functions. They were discovered by **Vincenzo Riccati** and **Lambert**.

3.1. Hyperbolic functions and exponent. We define the hyperbolic sine and cosine functions using exponents.

Definition 3.1. We define *hyperbolic functions*

$$(60) \quad \sinh(x) = \frac{1}{2}(e^x - e^{-x}), \quad \cosh(x) = \frac{1}{2}(e^x + e^{-x}), \quad \tanh(x) = \frac{\sinh(x)}{\cosh(x)}.$$

Note, that \sinh and \tanh are *odd functions* (that is $f(-x) = -f(x)$) and \cosh is *even function* (that is $f(-x) = f(x)$), the same as with the trigonometric \sin , \cos and \tan . This may be used to recover which function is defined through a sum of exponents and which one with the difference.

Sometimes we also write

$$(61) \quad \operatorname{cosech}(x) = \frac{1}{\sinh(x)}, \quad \operatorname{sech}(x) = \frac{1}{\cosh(x)}, \quad \operatorname{coth}(x) = \frac{1}{\tanh(x)}.$$

We can show from the definitions that

$$(62) \quad \cosh^2 x - \sinh^2 = 1,$$

since

$$\begin{aligned} \cosh^2 x - \sinh^2 &= \frac{1}{4}(e^x + e^{-x})^2 - \frac{1}{4}(e^x - e^{-x})^2 \\ &= \frac{1}{4}(e^{2x} + 2 + e^{-2x}) - \frac{1}{4}(e^{2x} - 2 + e^{-2x}) = 1. \end{aligned}$$

Dividing (62) by $\cosh^2 x$ we also have

$$1 - \tanh^2 x = \operatorname{sech}^2 x.$$

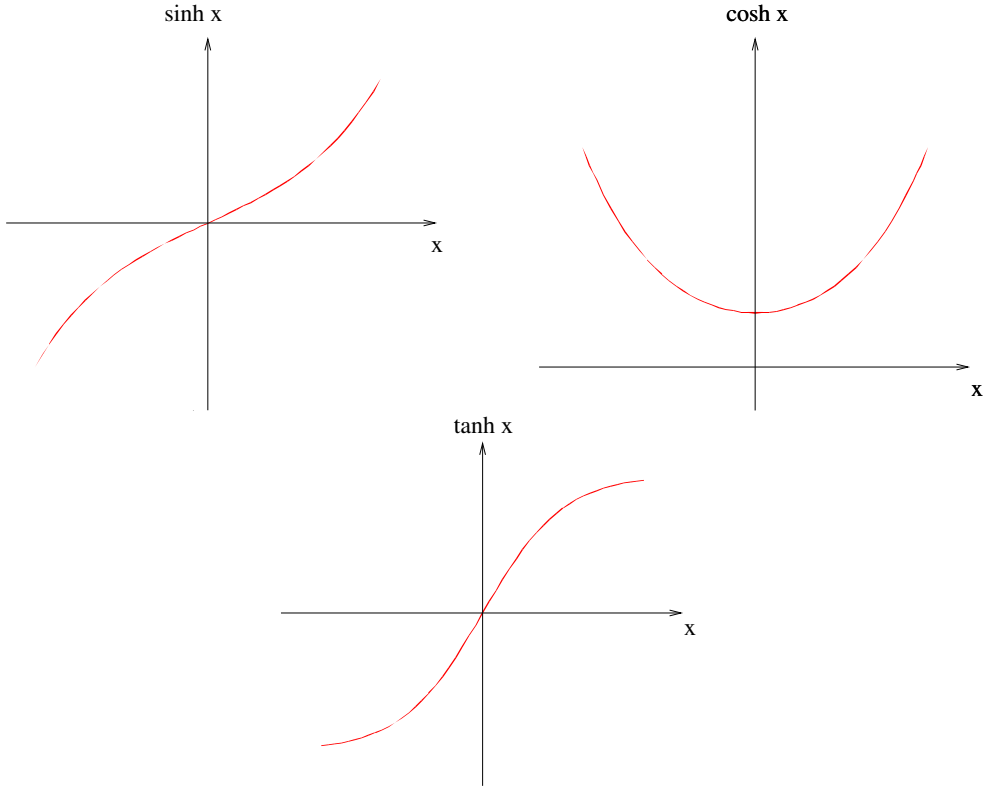

FIGURE 8. Graphs of hyperbolic functions.

We see that the formulae relating the hyperbolic functions are often the same as for the trigonometric functions, with some sign changes. The important difference between hyperbolic and trigonometric functions is that former are *not* periodic.

The derivatives of these functions are:

$$(63) \quad \frac{d}{dx} \sinh(x) = \frac{d}{dx} \frac{1}{2}(e^x - e^{-x}) = \frac{1}{2}(e^x + e^{-x}) = \cosh(x),$$

$$(64) \quad \frac{d}{dx} \cosh(x) = \frac{d}{dx} \frac{1}{2}(e^x + e^{-x}) = \frac{1}{2}(e^x - e^{-x}) = \sinh(x),$$

$$\frac{d}{dx} \tanh(x) = \frac{d}{dx} \frac{\sinh(x)}{\cosh(x)} = 1 - \frac{\sinh^2(x)}{\cosh^2(x)}.$$

Using (62), we get

$$(65) \quad \frac{d}{dx} \tanh(x) = \frac{1}{\cosh^2(x)} = \operatorname{sech}^2(x),$$

from (61b).

Note that $\tanh(x) \rightarrow -1$ as $x \rightarrow -\infty$, and $\tanh(x) \rightarrow 1$ as $x \rightarrow \infty$.

3.2. Inverse hyperbolic functions.

Definition 3.2. Define the *inverse hyperbolic functions* in the standard way i.e.

$$(66) \quad y = \sinh^{-1}(x) \quad \Rightarrow \quad x = \sinh(y),$$

$$(67) \quad y = \cosh^{-1}(x) \quad \Rightarrow \quad x = \cosh(y),$$

$$(68) \quad y = \tanh^{-1}(x) \quad \Rightarrow \quad x = \tanh(y),$$

Again we have to be careful with the domain and range, see Fig. 8. The inverse functions are well defined if:

$$\sinh^{-1}(x) \quad \text{Domain } -\infty < x < \infty \quad \text{Range } -\infty < y < \infty$$

$$\cosh^{-1}(x) \quad \text{Domain } 1 \leq x < \infty \quad \text{Range } 0 \leq y < \infty$$

$$\tanh^{-1}(x) \quad \text{Domain } -1 < x < 1 \quad \text{Range } -\infty < y < \infty$$

We can get the derivatives of these functions as for the inverse trigonometric functions e.g.

$$y = \sinh^{-1}(x) \quad \Rightarrow \quad \sinh(y) = x.$$

Differentiating gives

$$\cosh(y) \frac{dy}{dx} = 1.$$

Hence

$$(69) \quad \frac{d}{dx} \sinh^{-1}(x) = \frac{dy}{dx} = \frac{1}{\cosh(y)} = \frac{1}{[1 + \sinh^2(y)]^{1/2}} = \frac{1}{(1 + x^2)^{1/2}},$$

from (62).

Similarly we get

$$(70) \quad \frac{d}{dx} \cosh^{-1}(x) = \frac{1}{(x^2 - 1)^{1/2}},$$

$$(71) \quad \frac{d}{dx} \tanh^{-1}(x) = \frac{1}{1 - x^2},$$

We can get explicit expressions for these functions. We have

$$y = \sinh^{-1}(x) \quad \Rightarrow \quad \sinh(y) = \frac{1}{2}(e^y - e^{-y}) = x.$$

Then

$$e^{2y} - 2xe^y - 1 = 0.$$

Put $z = e^y$ to get $z^2 - 2xz - 1 = 0$. Solving this gives

$$z = e^y = x \pm \sqrt{x^2 + 1}.$$

So

$$(72) \quad y = \sinh^{-1}(x) = \ln(x + \sqrt{x^2 + 1}).$$

The right-hand side of (72) is known as “long” logarithm.

Note that we must take the + sign since $x < \sqrt{x^2 + 1}$ and we cannot take the logarithm of a negative number.

Similarly, we get

$$(73) \quad \cosh^{-1}(x) = \ln(x + \sqrt{x^2 - 1}) \quad \text{provided } x \geq 1.$$

Note the restriction on x : $\cosh y \geq 1$ for all y .

Suppose now that $y = \tanh^{-1}(x)$. Then

$$\tanh(y) = \frac{e^y - e^{-y}}{e^y + e^{-y}} = x.$$

Then

$$\frac{e^{2y} - 1}{e^{2y} + 1} = x \quad \Rightarrow \quad e^{2y} = \frac{1+x}{1-x} \quad \Rightarrow \quad y = \frac{1}{2} \ln\left(\frac{1+x}{1-x}\right).$$

Hence

$$(74) \quad \tanh^{-1}(x) = \frac{1}{2} \ln\left(\frac{1+x}{1-x}\right) \quad \text{provided } |x| < 1.$$

Note the restriction on x . The right-hand side of (74) is known as “tall” logarithm.

As for the inverse trigonometric functions, these results tell us how to do certain types of integrals.

For example, from (69) we can say that

$$\int \frac{dx}{\sqrt{1+x^2}} = \sinh^{-1}(x) + C.$$

We can also see this by substitution. Let $x = \sinh u$, $dx = \cosh u \, du$, so the integral becomes

$$\int \frac{1}{\sqrt{1+\sinh^2 u}} \cosh u \, du = \int du = u + C = \sinh^{-1} x + C = \ln(x + \sqrt{x^2 + 1}) + C.$$

Example 3.3. It is instructive to compare this set of examples with Example 2.24 and observe the explicit similarities.

(1) $\int \frac{dx}{\sqrt{x^2 - a^2}}$. Put $x = a \cosh(\theta)$. Then $dx = a \sinh(\theta) d\theta$. We get

$$\int \frac{dx}{\sqrt{x^2 - a^2}} = \int \frac{a \sinh(\theta)}{\sqrt{a^2 \cosh^2(\theta) - a^2}} d\theta = \int \frac{\sinh(\theta)}{\sinh(\theta)} d\theta = \int d\theta = \theta + C,$$

where we have used $\cosh^2(x) - \sinh^2(x) = 1$ (62). We therefore get

$$(75) \quad \int \frac{dx}{\sqrt{x^2 - a^2}} = \cosh^{-1}\left(\frac{x}{a}\right) + C.$$

(2) Now try $\int \frac{dx}{\sqrt{x^2 + 6x + 5}}$. We have $x^2 + 6x + 5 = (x + 3)^2 - 4$, so let's put $u = x + 3$ and $du = dx$, so we get $\int \frac{du}{\sqrt{u^2 - 4}}$.

From 1, with $a = 2$, this is $\cosh^{-1} \frac{u}{2} + C$, i.e., $\cosh^{-1} \frac{x+3}{2} + C$.

(3) $\int \frac{dx}{\sqrt{x^2 + a^2}}$. Put $x = a \sinh(\theta)$. Then $dx = a \cosh(\theta)d\theta$. We get

$$\int \frac{dx}{\sqrt{x^2 + a^2}} = \int \frac{a \cosh(\theta)}{\sqrt{a^2 \sinh^2(\theta) + a^2}} d\theta = \int \frac{\cosh(\theta)}{\cosh(\theta)} d\theta = \int d\theta = \theta + C,$$

where we have used $\cosh^2(x) - \sinh^2(x) = 1$ (62). We therefore get

$$(76) \quad \int \frac{dx}{\sqrt{x^2 + a^2}} = \sinh^{-1} \left(\frac{x}{a} \right) + C.$$

(4) Now try $\int \frac{dx}{\sqrt{x^2 + 2x + 10}}$. Since $x^2 + 2x + 10 = (x + 1)^2 + 9$, we put $u = x + 1$, so $du = dx$, to get $\int \frac{du}{\sqrt{u^2 + 9}}$.

From 3 with $a = 3$ this is $\sinh^{-1} \frac{u}{3} + C$, i.e. $\sinh^{-1} \frac{x+1}{3} + C$.

(5) $\int \frac{dx}{a^2 - x^2}$, for $|x| < a$. Put $x = a \tanh(\theta)$. Then $dx = a \operatorname{sech}^2(\theta)d\theta$. We get

$$\int \frac{dx}{a^2 - x^2} = \int \frac{a \operatorname{sech}^2(\theta)}{a^2[1 - \tanh^2(\theta)]} d\theta = \int \frac{\operatorname{sech}^2(\theta)}{a \operatorname{sech}^2(\theta)} d\theta = \int \frac{d\theta}{a} = \frac{\theta}{a} + C,$$

where we have used $\cosh^2(x) - \sinh^2(x) = 1$ (62), so $1 - \tanh^2 x = \operatorname{sech}^2 x$. We therefore get

$$(77) \quad \int \frac{dx}{a^2 - x^2} = \frac{1}{a} \tanh^{-1} \left(\frac{x}{a} \right) + C.$$

This could also be done using partial fractions. Write

$$\frac{1}{a^2 - x^2} = \frac{A_1}{a - x} + \frac{A_2}{a + x},$$

so $1 = A_1(a + x) + A_2(a - x)$. Put $x = a$ and $x = -a$ to find A_1 and A_2 .

This gives $A_1 = A_2 = \frac{1}{2a}$, so

$$\begin{aligned} \int \frac{dx}{a^2 - x^2} &= \frac{1}{2a} \int \left[\frac{1}{a-x} + \frac{1}{a+x} \right] dx \\ &= \frac{1}{2a} [\ln|a+x| - \ln|a-x|] \\ &= \frac{1}{2a} \ln \left| \frac{a+x}{a-x} \right| \\ &= \frac{1}{2a} \ln \left(\frac{a+x}{a-x} \right); \end{aligned}$$

we remove the absolute value signs because $-a < x < a$ implies that $\frac{a+x}{a-x} > 0$. This should be the same as (77). From (74) we have

$$\frac{1}{a} \tanh^{-1} \left(\frac{x}{a} \right) = \frac{1}{2a} \ln \left(\frac{a+x}{a-x} \right) = \frac{1}{2a} [\ln(a+x) - \ln(a-x)]$$

which agrees with our previous result.

3.3. Summary of useful substitutions. Here we list some common expressions and methods suitable for their integration.

$\int \frac{1}{x^2 - a^2} dx$ (or anything that factorizes). Partial fractions (the substitution $x = a \tanh t$ works as well).

$\int \frac{1}{x^2 + a^2} dx$. Put $x = a \tan \theta$.

$\int \frac{x}{x^2 \pm a^2} dx$. Put $u = x^2 \pm a^2$.

$\int \frac{1}{\sqrt{a^2 - x^2}} dx$ (or some other expression of $\sqrt{a^2 - x^2}$). Put $x = a \sin \theta$.

$\int \frac{1}{\sqrt{a^2 + x^2}} dx$ (or some other expression of $\sqrt{a^2 + x^2}$). Put $x = a \sinh \theta$.

$\int \frac{1}{\sqrt{x^2 - a^2}} dx$ (or some other expression of $\sqrt{x^2 - a^2}$). Put $x = a \cosh \theta$.

$\int \frac{x}{\sqrt{x^2 \pm a^2}} dx$. Put $u = x^2 \pm a^2$.

4. APPLICATIONS OF INTEGRALS

We will show some applications of integrals to geometric problems.

4.1. Areas. Since the definite integral is defined as an area, we can use it to calculate the areas of different shapes.

4.1.1. Circle. We have already found the area of a circle by elementary considerations in the beginning of Section 1. Now we solve this question again using integration technique.

Consider a quarter of the circle centre $(0,0)$, radius R . The equation is $x^2 + y^2 = R^2$, i.e., $y = \sqrt{R^2 - x^2}$.

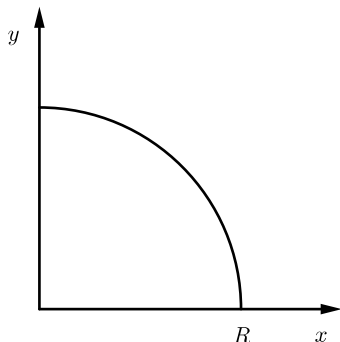

FIGURE 9. Area of a circle

So the area is $A = \int_0^R \sqrt{R^2 - x^2} dx$.

To evaluate this integral, put $x = R \sin \theta$. Then $dx = R \cos \theta$ and the new limits are $x = 0, \theta = 0, x = R, \theta = \pi/2$.

Then

$$\begin{aligned}
 \int_0^R \sqrt{R^2 - x^2} dx &= \int_0^{\pi/2} R^2 \sqrt{1 - \sin^2 \theta} \cos \theta d\theta \\
 &= \int_0^{\pi/2} R^2 \cos^2 \theta d\theta \\
 &= \int_0^{\pi/2} R^2 \left(\frac{1}{2} + \frac{1}{2} \cos 2\theta \right) d\theta = \left[\frac{R^2 \theta}{2} + \frac{R^2}{4} \sin(2\theta) \right]_0^{\pi/2} \\
 (78) \qquad &= \frac{\pi R^2}{4}
 \end{aligned}$$

This gives the area of the whole circle πR^2 as expected.

There is an easier way to do it. Consider a the strip shown on Fig. 10 with width δr .

Its area is $\delta A = \frac{\pi r}{2} \delta r$ ("the product of its width by depth"), so

$$A = \int_0^R \frac{\pi r}{2} dr = \left[\frac{\pi r^2}{4} \right]_0^R = \frac{\pi R^2}{4}.$$

4.1.2. *Ellipse.* Consider a quarter of the ellipse $\frac{x^2}{a^2} + \frac{y^2}{b^2} = 1$, or $y = b\sqrt{1 - x^2/a^2}$.

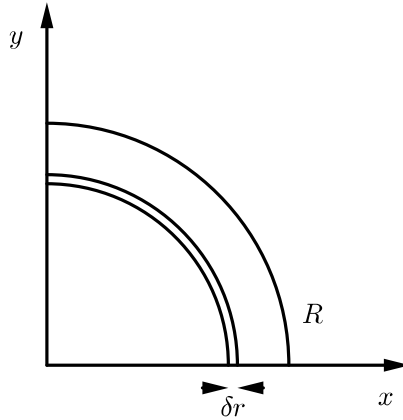

FIGURE 10. Circular strip

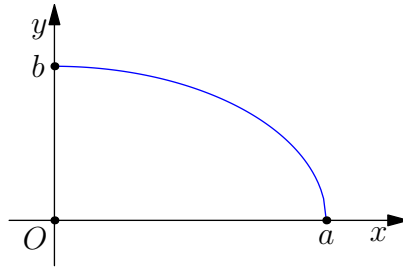

FIGURE 11. Area of an ellipse

So the area is $A = \int_0^a b\sqrt{1 - x^2/a^2} dx$.

Put $x = a \sin \theta$. Then $dx = a \cos \theta$ and new limits are $x = 0, \theta = 0, x = a, \theta = \pi/2$. Then

$$\begin{aligned} \int_0^a b\sqrt{1 - x^2/a^2} dx &= \int_0^{\pi/2} ab\sqrt{1 - \sin^2 \theta} \cos \theta d\theta \\ &= \int_0^{\pi/2} ab \cos^2 \theta d\theta = \left[\frac{ab\theta}{2} + \frac{ab}{4} \sin(2\theta) \right]_0^{\pi/2}. \end{aligned}$$

This gives $A = \frac{\pi ab}{4}$ as expected. Note, that for $a = b$ the ellipse becomes a circle of the radius a , then the above answer coincides with (78).

4.1.3. Area under Curves.

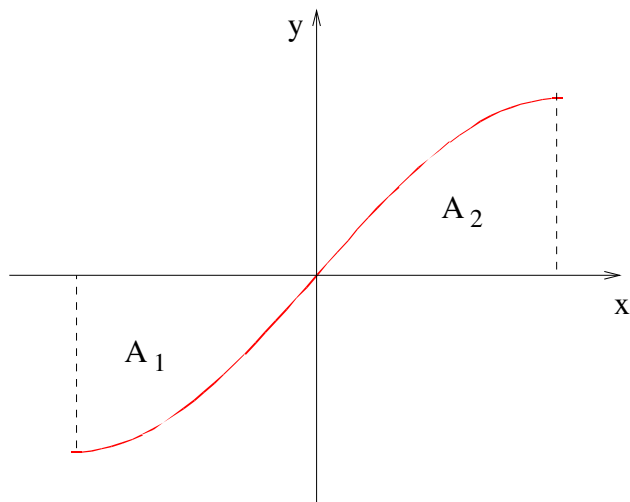

FIGURE 12. Area under the graph of sine

Example 4.1. The area between $\sin x$ and the x -axis for $-\pi/2 \leq x \leq \pi/2$.

This is $A = A_1 + A_2$. But $\int_{-\pi/2}^{\pi/2} \sin x \, dx = [-\cos x]_{-\pi/2}^{\pi/2} = 0$.

This is because areas with negative y are counted as negative. To get the right answer we have to write

$$A = \int_{-\pi/2}^{\pi/2} |\sin x| \, dx = \int_{-\pi/2}^0 -\sin x \, dx + \int_0^{\pi/2} \sin x \, dx = 2 \int_0^{\pi/2} \sin x \, dx = 2[-\cos x]_0^{\pi/2} = 2.$$

Example 4.2. The area between $y = x$ and $y = x^2$ for $0 \leq x \leq 1$.

$$\text{This is } A = \int_0^1 (x - x^2) \, dx = \left[\frac{x}{2} - \frac{x^3}{3} \right]_0^1 = \frac{1}{2} - \frac{1}{3} = \frac{1}{6}.$$

In general the area between two curves, $y = f(x)$ and $y = g(x)$, with x running from a to b is

$$\int_a^b |f(x) - g(x)| \, dx,$$

and the way to do this is to split the range into interval in which $f(x) \geq g(x)$ or $f(x) \leq g(x)$.

So, in our example, if we wanted the area from $0 \leq x \leq 2$ we would need to split the range of integration into two pieces, on one of which $x \geq x^2$ and on the other $x^2 \geq x$, so

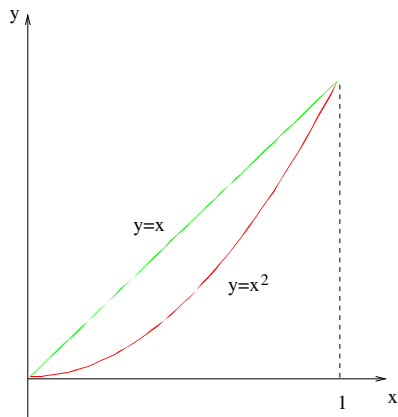

FIGURE 13. Area under a parabola

we would get

$$\int_0^1 (x - x^2) dx + \int_1^2 (x^2 - x) dx.$$

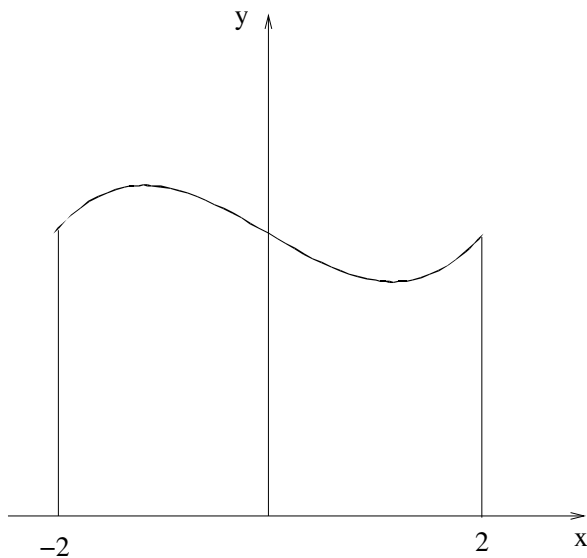

FIGURE 14. Area under a curve

Example 4.3. The area between $y = x^3 - 4x + 15$ and the x -axis for $-2 \leq x \leq 2$.

$$\text{This is } A = \int_{-2}^2 (x^3 - 4x + 15) dx = \left[\frac{x^4}{4} - 2x^2 + 15x \right]_{-2}^2 =$$

$$= 4 - 8 + 30 - 4 + 8 + 30 = 60.$$

4.2. Volumes. One can also use integration to calculate volumes, but this complicated in the general case. However, it is not too difficult if the object has some symmetry.

4.2.1. Volumes of Revolution. For any curve $y = f(x)$, we can form a solid of revolution by rotating the curve about the x -axis.

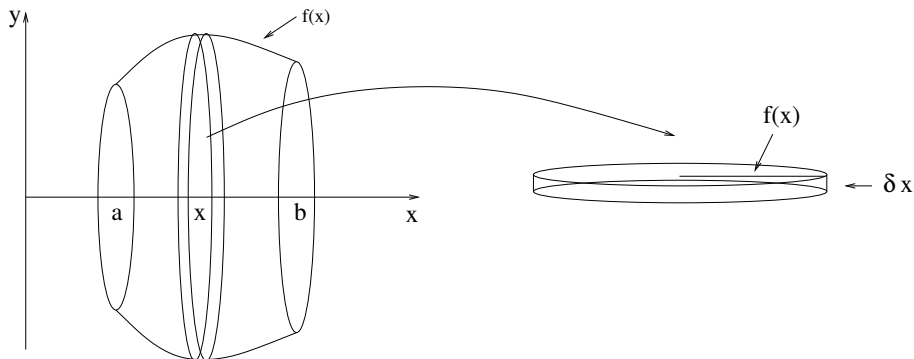

FIGURE 15. Integration of rotation solids

If we cut out a disc at x with thickness δx by slicing the solid perpendicular to the x -axis. This disc has radius $f(x)$ and so has volume $\delta V = \pi y^2 \delta x$. Hence if the body lies between $x = a$ and $x = b$, then its volume is

$$(79) \quad V = \int_a^b \pi y^2 dx = \int_a^b \pi [f(x)]^2 dx.$$

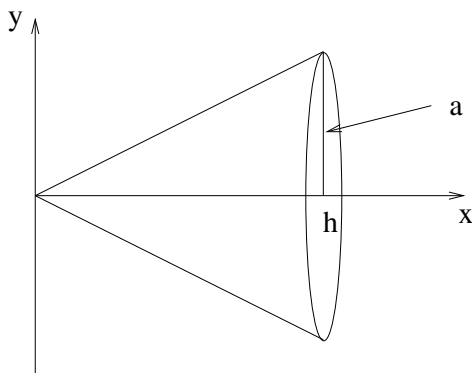

FIGURE 16. Volume of a cone

Example 4.4. Consider a cone whose height is h and whose base has radius a .

In this case $f(x) = \frac{ax}{h}$ and (79) gives

$$(80) \quad \int_0^h \pi \frac{a^2 x^2}{h^2} dx = \pi \frac{a^2}{h^2} \left[\frac{x^3}{3} \right]_0^h = \frac{1}{3} \pi a^2 h.$$

Note this is $1/3$ of the volume of a cylinder with the same base and height.

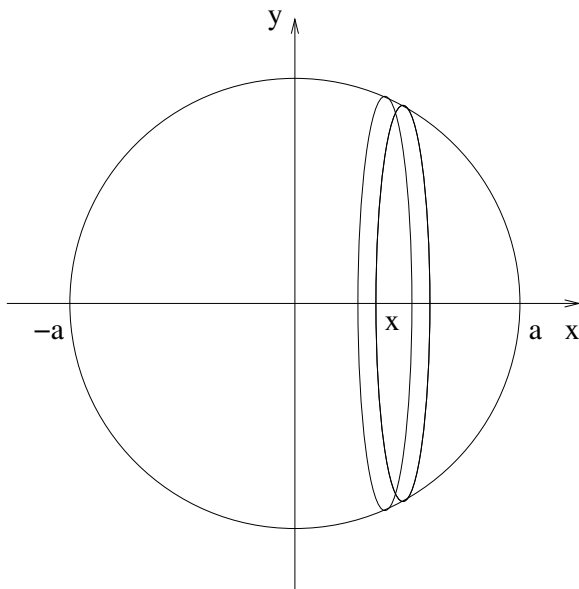

FIGURE 17. Volume of a sphere

Example 4.5. Consider a sphere of radius a . This is obtained by rotating a half-circle with radius a .

In this case $f(x) = \sqrt{a^2 - x^2}$ and (79) gives

$$(81) \quad V = \int_{-a}^a \pi (a^2 - x^2) dx = \pi \left[a^2 x - \frac{x^3}{3} \right]_{-a}^a = \frac{4\pi}{3} a^3.$$

Note that V is a function of a , and that $\frac{dV}{da} = 4\pi a^2$. So, if we add a thin shell of thickness δa , we increase the volume by $4\pi a^2 \delta a$. This suggests (and leads to a proof) that the area of the surface of the sphere is $4\pi a^2$.

The next example shows that integrals can be used not only for solids of revolution.

Example 4.6. Consider a pyramid of height h , base with side a . The cross-section at x is a square with side $\frac{xa}{h}$. So a slice at x with thickness δx has volume $\delta V = \left(\frac{xa}{h} \right)^2 \delta x$. The

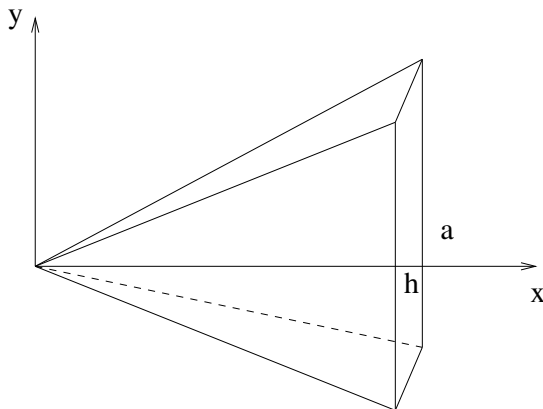

FIGURE 18. Volume of a pyramid

volume is then

$$(82) \quad \int_0^h dV = \int_0^h \left(\frac{xa}{h}\right)^2 dx = \frac{a^2}{h^2} \left[\frac{x^3}{3}\right]_0^h = \frac{a^2 h}{3}.$$

Note, that this is $1/3$ of the volume of a rectangular block with same base and height. Also, similar calculations can be used for the volume of a pyramid with the base of an arbitrary shape, cf. Example 4.4.

Example 4.7. Find the volume of the torus (or “ring”) obtained by rotating the disc

$$x^2 + (y - 1)^2 = \frac{1}{4}$$

about the x -axis. This is a circle with centre $(0, 1)$ and radius $1/2$.

The equation of the top semi-circle is $y = 1 + \sqrt{\frac{1}{4} - x^2}$, and of the bottom semi-circle is $y = 1 - \sqrt{\frac{1}{4} - x^2}$; in each case for $-1/2 \leq x \leq 1/2$. To get the volume we want we subtract the two volumes, to get

$$V = \pi \int_{-1/2}^{1/2} \left(1 + \sqrt{\frac{1}{4} - x^2}\right)^2 - \left(1 - \sqrt{\frac{1}{4} - x^2}\right)^2 dx.$$

This simplifies to

$$V = 4\pi \int_{-1/2}^{1/2} \sqrt{\frac{1}{4} - x^2} dx.$$

Put $x = \frac{1}{2} \sin \theta$, $dx = \frac{1}{2} \cos \theta d\theta$, to get

$$\begin{aligned} V &= 4\pi \int_{-\pi/2}^{\pi/2} \left(\frac{1}{2} \cos \theta \right) \frac{1}{2} \cos \theta d\theta \\ &= \pi \int_{-\pi/2}^{\pi/2} \left(\frac{1}{2} + \frac{1}{2} \cos 2\theta \right) d\theta \\ &= \pi \left[\frac{\theta}{2} + \frac{1}{4} \sin 2\theta \right]_{-\pi/2}^{\pi/2} = \pi(\pi/4 - (-\pi/4)) = \frac{\pi^2}{2}. \end{aligned}$$

Example 4.8. Consider the curve $y = 1/(x + 1)$ with $x \geq 0$. Show that the total area enclosed by it and the x -axis is infinite, and find the volume of the solid obtained by rotating the area about the x -axis.

First, the area underneath is

$$\int_0^{\infty} \frac{1}{x+1} dx = [\ln(x+1)]_0^{\infty} = \infty,$$

since $\ln(x+1)$ tends to $+\infty$ as x tends to $+\infty$.

Surprisingly, the volume is finite: it is

$$V = \pi \int_0^{\infty} \frac{1}{(x+1)^2} dx = \pi \left[-\frac{1}{x+1} \right]_0^{\infty} = \pi(0 - (-1)) = \pi.$$

In other words, to “make” such a body of revolution we would need only a finite amount of material, but to colour its surface we would need an infinite amount of paint.

5. BINOMIAL COEFFICIENTS AND POLYNOMIALS

5.1. Binomial Coefficients.

Definition 5.1. The *binomial (or combinatorial) coefficients*, denoted as $\binom{n}{r}$, are the number of ways one can pick r elements from a set of n elements. The symbol $\binom{n}{r}$ is read as “ n choose r ”.

They can also be written as ${}^n C_r$ (from *combinations* or *choices*) and many other similar notations.

Recall the fundamental principle of combinatorics—the *rule of product* or *multiplication principle*—a basic counting principle: if there are n ways of doing something and m ways of doing another thing independently, then there are $n \cdot m$ ways of performing both actions.

To find a formula for $\binom{n}{r}$, first consider the number of ways that we can order n elements. This is also called the number of *permutations* of the n elements.

We can choose the 1st element in n ways.

We can choose the 2nd element in $n - 1$ ways.

We can choose the 3rd element in $n - 2$ ways.

⋮

We can choose the last element in 1 way.

So the total number of ways is

$$(83) \quad n! = n(n-1)(n-2) \cdots 1.$$

This is called n *factorial*. For a convenience we define $0! = 1$. Note, the important *recurrence relation* for factorials:

$$(84) \quad n! = (n-1)! \cdot n.$$

This formula together with the initial value $0! = 1$ is equivalent to the definition (83).

Now suppose that we want to pick r elements from a set of n elements if the order in which they are picked matters.

We can choose the 1st element in n ways.

We can choose the 2nd element in $n - 1$ ways.

We can choose the 3rd element in $n - 2$ ways.

⋮

We can choose the last element in $n - r + 1$ ways,

since we have $n - r + 1$ elements left when we pick the last one. From the definition of the factorial this is

$$(85) \quad {}^n P_r = \frac{n!}{(n-r)!}$$

For $\binom{n}{r}$, we do not care about the order of the elements. So we must have

$$(86) \quad \binom{n}{r} = \frac{{}^n P_r}{r!} = \frac{n!}{r!(n-r)!}$$

since $r!$ is the number of ways in which we can order each set of r elements.

Note that

$$(87) \quad \binom{n}{n} = \binom{n}{0} = 1,$$

because there is only one way how to to chose all n elements or none of them. Also:

$$(88) \quad \binom{n}{r} = \binom{n}{n-r}.$$

This is easy to see:

$$\binom{n}{n-r} = \frac{n!}{(n-r)!(n-n+r)!} = \frac{n!}{r!(n-r)!} = \binom{n}{r}.$$

Remark 5.2. Traditionally, we name Pascal's triangle after **Blaise Pascal**. However it was known much earlier to Indian, Persian and Chinese mathematicians, e.g. **Al-Karaji** and **Shen Kuo**.

5.3. The Binomial Theorem. $\binom{n}{r}$ are called the *binomial coefficients* because they are the coefficients in the expansion of $(a + b)^n$. We have

$$(90) \quad (a + b)^n = \sum_{r=0}^n \binom{n}{r} a^{n-r} b^r.$$

The binomial theorem is commonly attributed to **Newton**.

So

$$\begin{aligned} (a + b)^2 &= a^2 + 2ab + b^2, \\ (a + b)^3 &= a^3 + 3a^2b + 3ab^2 + b^3, \\ (a + b)^4 &= a^4 + 4a^3b + 6a^2b^2 + 4ab^3 + b^4, \end{aligned}$$

and so on.

To see this in general, we note that each term in the expansion consists of n factors each of which is either a or b . Consider one such term, $a^{n-r}b^r$. We have

$$(a + b)^n = (a + b)(a + b) \cdots (a + b),$$

i.e., a product of n factors $a + b$. To get the term $a^{n-r}b^r$, we have to pick a from $n - r$ factors and b from r factors. This is just picking r elements (the b) from n elements i.e. $\binom{n}{r}$ by definition.

For example, consider

$$(a + b)^3 = (a + b)(a + b)(a + b).$$

To get a^3 we have to pick a from each factor, i.e., no b . This is done in $\binom{3}{0} = 1$ way.

To get a^2b we have to pick a from 2 factors and b from 1 factor. This is done in $\binom{3}{1} = 3$ ways.

To get ab^2 we have to pick a from 1 factors and b from 2 factors. This is done in $\binom{3}{2} = 3$ ways.

To get b^3 we have to pick b from each factor, i.e., no a . This is done in $\binom{3}{3} = 1$ way.

So

$$(a + b)^3 = a^3 + 3a^2b + 3ab^2 + b^3.$$

Example 5.3. Expand $(a - b)^4$. Use the binomial theorem (89); we get

$$\begin{aligned} (a - b)^4 &= \sum_{r=0}^4 \binom{4}{r} a^{4-r} (-b)^r \\ &= \binom{4}{0} a^4 + \binom{4}{1} a^3(-b) + \binom{4}{2} a^2(-b)^2 + \binom{4}{3} a(-b)^3 + \binom{4}{4} (-b)^4. \end{aligned}$$

We have

$$\binom{4}{0} = 1, \quad \binom{4}{1} = \frac{4!}{1!3!} = 4, \quad \binom{4}{2} = \frac{4!}{2!2!} = 6, \quad \binom{4}{3} = \frac{4!}{3!1!} = 4, \quad \binom{4}{4} = 1.$$

So

$$(a - b)^4 = a^4 - 4a^3b + 6a^2b^2 - 4ab^3 + b^4.$$

Example 5.4. Expand $(a + 3b)^3$ by the binomial theorem: we get

$$\begin{aligned} (a + 3b)^3 &= \sum_{r=0}^3 \binom{3}{r} a^{3-r} (3b)^r \\ &= \binom{3}{0} a^3 + \binom{3}{1} a^2 (3b)^1 + \binom{3}{2} a^1 (3b)^2 + \binom{3}{3} (3b)^3 \\ &= (1)(a^3) + (3)(3a^2b) + (3)(9ab^2) + (1)(27b^3) \\ &= a^3 + 9a^2b + 27ab^2 + 27b^3. \end{aligned}$$

Example 5.5. As a connection with the main theme of this course let us integrate both sides of the binomial formula (90) for $(x + a)^n$ where x is a variable, a is a constant and n is a natural number. Then for the right-hand side the substitution $u = x + a$ do the job:

$$\int (x + a)^n dx = \int u^n du = \frac{1}{n+1} u^{n+1} + C = \frac{1}{n+1} (x + a)^{n+1} + C_1.$$

For the left-hand side we use additivity (11) and homogeneity (12) of the integral:

$$\begin{aligned} \int \sum_{r=0}^n \binom{n}{r} x^{n-r} a^r dx &= \sum_{r=0}^n \int \binom{n}{r} x^{n-r} a^r dx \\ &= \sum_{r=0}^n \binom{n}{r} a^r \int x^{n-r} dx \\ &= \sum_{r=0}^n \binom{n}{r} a^r \frac{1}{n-r+1} x^{n-r+1} + C_2. \end{aligned}$$

In other words, we shall have:

$$\frac{1}{n+1} (x + a)^{n+1} + C_1 = \sum_{r=0}^n \frac{1}{n-r+1} \binom{n}{r} x^{n-r+1} a^r + C_2.$$

or using the binomial formula (90) for $(x + a)^{n+1}$

$$\frac{1}{n+1} \sum_{r=0}^{n+1} \binom{n+1}{r} x^{n+1-r} a^r + C_1 = \sum_{r=0}^n \frac{1}{n-r+1} \binom{n}{r} x^{n-r+1} a^r + C_2.$$

The left- and right-hand side of the last identity are similar, but you still need to check that:

$$(1) \frac{1}{n+1} \binom{n+1}{r} = \frac{1}{n-r+1} \binom{n}{r}.$$

(2) The term for $r = n + 1$ missing in the right-hand sum shall be equal to $C_2 - C_1$.

6. SOME REVISION EXAMPLES

We revise different examples for many previous methods.

6.1. Polynomial Division. We mentioned earlier in Section 2.4, that if $P(x)$ is an n th order polynomial and $Q(x)$ is an m th order polynomial, then we could write

$$(91) \quad P(x) = N(x)Q(x) + R(x), \quad \text{or equivalently:} \quad \frac{P(x)}{Q(x)} = N(x) + \frac{R(x)}{Q(x)},$$

where

- $N(x)$ (the quotient) is an $(n - m)$ th order polynomial if $n \geq m$ and 0 otherwise;
- $R(x)$ (the remainder) is at most an $(m - 1)$ th order polynomial, thus the rational function $\frac{R(x)}{Q(x)}$ is proper.

We can find $N(x)$ and $R(x)$ by either:

- equating coefficients of powers of x ; or
- by a method of long (polynomial) division.

Example 6.1. Find the quotient and remainder for $x^4 - 2x^3 - 7x^2 + x + 40$ is divided by $x^2 - 6x + 10$.

$$\begin{array}{r} x^2 + 4x + 7 \\ x^2 - 6x + 10 \overline{) x^4 - 2x^3 - 7x^2 + x + 40} \\ \underline{x^4 - 6x^3 + 10x^2} \\ 4x^3 - 17x^2 + x \quad \text{See (1) below} \\ \underline{4x^3 - 24x^2 + 40x} \quad \text{See (2) below} \\ 7x^2 - 39x + 40 \quad \text{See (3) below} \\ \underline{7x^2 - 42x + 70} \\ 3x - 30 \end{array}$$

The sequence of steps (that is the *algorithm*) is:

- (1) DIVIDE the highest term remaining by x^2 (e.g. $4x^3/x^2 = 4x$);
- (2) MULTIPLY everything in the divisor by what you got, so

$$4x(x^2 - 6x + 10) = 4x^3 - 24x^2 + 40x;$$

- (3) SUBTRACT, and notice that this reduces the degree of what's remaining.

So the quotient is $N = x^2 + 4x + 7$, and the remainder is $R = 3x - 30$.

Now

$$\int \frac{x^4 - 2x^3 - 7x^2 + x + 40}{x^2 - 6x + 10} dx = \int (x^2 + 4x + 7) dx + \int \frac{3x - 30}{x^2 - 6x + 10} dx.$$

The first integral is just $\frac{x^3}{3} + 2x^2 + 7x (+C)$, and for the second we complete the square, putting $u = x - 3$, since $x^2 - 6x + 10 = (x - 3)^2 + 1$. We get

$$\begin{aligned} \int \frac{3u - 21}{u^2 + 1} du &= 3 \int \frac{u}{u^2 + 1} du - 21 \int \frac{du}{u^2 + 1} \\ &= \frac{3}{2} \ln(u^2 + 1) - 21 \tan^{-1} u + C \\ &= \frac{3}{2} \ln(x^2 - 6x + 10) - 21 \tan^{-1}(x - 3) + C. \end{aligned}$$

So the final answer is

$$\frac{x^3}{3} + 2x^2 + 7x + \frac{3}{2} \ln(x^2 - 6x + 10) - 21 \tan^{-1}(x - 3) + C.$$

Example 6.2. Find the quotient and remainder for $2x^4 - 2x^3 - 15x^2 + 9x - 2$ is divided by $x^2 - 4x + 4$.

Hence find

$$\int \frac{2x^4 - 2x^3 - 15x^2 + 9x - 2}{x^2 - 4x + 4} dx.$$

$$x^2 - 4x + 4 \overline{) 2x^4 - 2x^3 - 15x^2 + 9x - 2}$$

$$\underline{2x^4 - 8x^3 + 8x^2}$$

$$6x^3 - 23x^2 + 9x$$

$$\underline{6x^3 - 24x^2 + 24x}$$

$$x^2 - 15x - 2$$

$$\underline{x^2 - 4x + 4}$$

$$-11x - 6$$

So the quotient is $N = 2x^2 + 6x + 1$ and the remainder is $R = -11x - 6$.

Now since $x^2 - 4x + 4 = (x - 2)^2$ we write

$$\frac{-11x - 6}{(x - 2)^2} = \frac{A}{x - 2} + \frac{B}{(x - 2)^2},$$

where $-11x - 6 = A(x - 2) + B$. Thus $A = -11$ and $B = -28$. So

$$\int \frac{2x^4 - 2x^3 - 15x^2 + 9x - 2}{x^2 - 4x + 4} dx = \int \left(2x^2 + 6x + 1 - \frac{11}{x - 2} - \frac{28}{(x - 2)^2} \right) dx$$

$$= \frac{2}{3}x^3 + 3x^2 + x - 11 \ln|x - 2| + \frac{28}{x - 2} + C.$$

6.2. Various examples.

Example 6.3. $\int (\ln x)^2 dx$. We try integration by parts: $\int f'g = fg - \int fg'$. Here we put $f(x) = 1$ and $g(x) = (\ln x)^2$.

This gives

$$\int (\ln x)^2 dx = x(\ln x)^2 - \int x \frac{2 \ln x}{x} dx$$

$$= x(\ln x)^2 - 2 \int \ln x dx$$

$$= x(\ln x)^2 - 2x(\ln x) + 2 \int x \frac{1}{x} dx, \quad \text{integrating by parts again,}$$

$$= x(\ln x)^2 - 2x(\ln x) + 2x + C.$$

Alternatively, the substitution $u = \ln x$, $x = e^u$, so $dx = e^u du$, turns the integral into

$$\int u^2 e^u du,$$

but you still need to integrate by parts to solve this. This is another illustration to the relation of integration by parts and integration by substitution discussed in subsection 2.3.1.

Example 6.4. $\int \frac{\sqrt{x}}{1+x} dx$.

The substitution $u = \sqrt{x}$ or $x = u^2$, $dx = 2u du$ turns this into

$$\begin{aligned} \int \frac{u}{1+u^2} (2u) du &= \int \frac{2u^2}{1+u^2} du \\ &= \int \left(2 - \frac{2}{1+u^2} \right) du, \quad \text{by long division or just observation,} \\ &= 2u - 2 \tan^{-1} u + C \\ &= 2\sqrt{x} - 2 \tan^{-1}(\sqrt{x}) + C. \end{aligned}$$

Example 6.5. $\int \frac{1}{1+\tan x} dx$.

You could use the $t = \tan x/2$ substitution, but it turns into a very complicated calculation. Instead,

$$\int \frac{1}{1+\tan x} dx = \int \frac{1}{1+\frac{\sin x}{\cos x}} dx = \int \frac{\cos x}{\sin x + \cos x} dx.$$

Now we have something of the form $\frac{P(x)}{Q(x)}$, where we can write $P = aQ + bQ'$ for some constants a and b . Indeed $Q'(x) = \cos x - \sin x$, so $P(x) = \frac{1}{2}(Q(x) + Q'(x))$, and

$$\begin{aligned} \int \frac{\cos x}{\sin x + \cos x} dx &= \frac{1}{2} \int \frac{\sin x + \cos x}{\sin x + \cos x} dx + \frac{1}{2} \int \frac{\cos x - \sin x}{\sin x + \cos x} dx \\ &= \frac{1}{2}x + \frac{1}{2} \ln |\sin x + \cos x| + C. \end{aligned}$$

Example 6.6. $\int \frac{x^2}{\sqrt{1-x^2}} dx$.

The $\sqrt{1-x^2}$ suggests a substitution $x = \sin u$, $dx = \cos u du$, so we get

$$\int \frac{x^2}{\sqrt{1-x^2}} dx = \int \frac{\sin^2 u}{\cos u} \cos u du = \int \sin^2 u du.$$

Now, we did this before using double angles:

$$\sin^2 u = \frac{1}{2}(1 - \cos 2u).$$

We get

$$\begin{aligned} \int \sin^2 u du &= \frac{1}{2}u - \frac{1}{4} \sin 2u = \frac{1}{2}u - \frac{1}{2} \sin u \cos u \\ &= \frac{1}{2} \sin^{-1} x - \frac{1}{2} x \sqrt{1-x^2} \quad (+C). \end{aligned}$$

APPENDIX A. TRIANGLES

Definition A.1. A *triangle* is a polygon with three sides (a polygon is a plane figure whose edges are straight lines), Fig. 19.

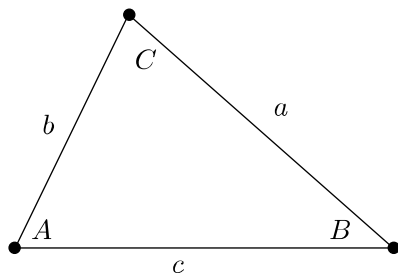

FIGURE 19. A triangle and notations: angles are A, B, C and the opposite sides are a, b, c.

A.1. Area of a Triangle. We will need the concept of *area* of a geometric figure. In particular, we note that *area is additive*: if a figure with an area S is split into two disjoint subfigures with areas S_1 and S_2 then $S = S_1 + S_2$.

We also assume the formulae for the area of a rectangle with sides a and b the area is $S = ab$.

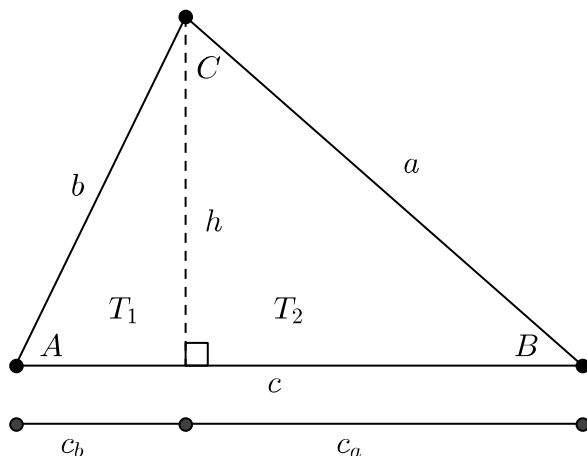

FIGURE 20. Basic relations in a triangle.

Here h is the height of the triangle in Fig. 20, it splits the side c into two intervals c_b and c_a . The area of the triangle is $T = T_1 + T_2$. But we have

$$T_1 = \frac{1}{2}hc_b, \quad T_2 = \frac{1}{2}hc_a,$$

since each is just half of a rectangle with these sides. So

$$(92) \quad T = T_1 + T_2 = \frac{1}{2}(c_b + c_a)h = \frac{1}{2}ch \quad \text{“half base times height”,}$$

since $c = c_a + c_b$.

A.2. Sine Rule. Trigonometric functions – sine and cosine – are intimately connected with the geometry of triangles.

We have $h = b \sin A$, so

$$T = \frac{1}{2}bc \sin A.$$

But we could also draw the perpendicular to sides b and a to get

$$T = \frac{1}{2}ab \sin C = \frac{1}{2}bc \sin B.$$

Dividing by $abc/2$ gives

$$(93) \quad \frac{\sin A}{a} = \frac{\sin B}{b} = \frac{\sin C}{c},$$

which is the *Sine Rule*.

Remark A.2. It is noteworthy that the value of fractions in (93) is the diameter of the circumscribed circle. Can you prove this?

The sine rule has been discovered by **Nasir al-Din al-Tusi** in XIII century.

Example A.3. Suppose we are given c and the angles A, B . We can use the Sine Rule to determine the other sides. Note that we know the angle C since

$$(94) \quad A + B + C = 180^\circ,$$

since the internal angles of a triangle add up to 180° .

We then have from (93)

$$\frac{\sin C}{c} = \frac{\sin A}{a} = \frac{\sin B}{b}.$$

Since we know C, c, A, B , this gives us a and b ; *i.e.*, everything about the triangle. For example, suppose

$$A = 32^\circ, \quad B = 65^\circ, \quad c = 9 \text{ cm.}$$

Then $C = 83^\circ$ and we have $\sin A = 0.5299$, $\sin B = 0.9063$, $\sin C = 0.9925$. (Let us suppose we want to give two decimal places for our answer: then we should keep at least four for the sines.) So we have

$$a = c \frac{\sin A}{\sin C} = 9 \frac{0.5299}{0.9925} = 4.81 \text{ cm}, \quad b = c \frac{\sin B}{\sin C} = 9 \frac{0.9063}{0.9925} = 8.22 \text{ cm.}$$

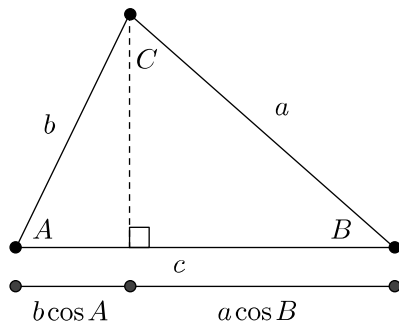

FIGURE 21. Relation between sides and cosines.

A.3. Cosine Rule. As shown on Fig. 21, we have $c = b \cos A + a \cos B$. Multiply this by c .

$$(95) \quad c^2 = bc \cos A + ac \cos B.$$

Similarly we get

$$(96) \quad a^2 = ab \cos C + ac \cos B$$

$$(97) \quad b^2 = bc \cos A + ab \cos C$$

Adding (96) and (97) gives

$$a^2 + b^2 = 2ab \cos C + bc \cos A + ac \cos B.$$

Subtracting (95) from this gives

$$a^2 + b^2 - c^2 = 2ab \cos C + bc \cos A + ac \cos B - bc \cos A - ac \cos B = 2ab \cos C.$$

Rearranging, we get

$$(98) \quad c^2 = a^2 + b^2 - 2ab \cos C,$$

which is the *Cosine Rule*. In a different form it was already published in [Euclid's Elements](#) (300 BC), but obtained the modern form in works [Jamshid al-Kashi](#) (XV century).

Corollary A.4 (Pythagoras theorem). If $C = 90^\circ$ (and thus $\cos C = 0$) we have:

$$(99) \quad c^2 = a^2 + b^2.$$

Example A.5. Suppose that we are given a , b and the angle C . We can use the Cosine Rule to determine c . For example, suppose

$$a = 8 \text{ cm}, \quad b = 9 \text{ cm}, \quad C = 48^\circ; \quad \text{i.e., } \cos C = 0.66913.$$

Then (98) gives

$$c^2 = 64 + 81 - 2 \times 8 \times 9 \times 0.66913 = 48.65, \quad \text{so } c = 6.97 \text{ cm}.$$

We can now use the Sine Rule and $A + B + C = 180^\circ$ to get the other angles.

Remark A.6. Note we could also use the Cosine Rule if we are given all three sides: just use (98) to get A, B given a, b, c . This gives a unique A (and B) since $-1 \leq \cos A \leq 1$ for $180^\circ \geq A \geq 0$.

These cases give a unique triangle. But if we are given two sides and an angle which is not the one between the sides then the triangle is not necessarily unique.

Suppose we are given a, b, A . Then from the Sine Rule (93), we have

$$\frac{\sin A}{a} = \frac{\sin B}{b}, \quad \text{so} \quad \sin B = \frac{b}{a} \sin A.$$

Unfortunately this does not give a unique B : we have two possibilities since $\sin(180^\circ - B) = \sin B$. This is because $\sin B$ has a maximum as B goes from 0° to 180° .

For example, suppose

$$a = 5 \text{ cm}, \quad b = 7 \text{ cm}, \quad A = 35^\circ.$$

We then get

$$\sin B = \frac{b}{a} \sin A = \frac{7}{5} 0.57358 = 0.80301,$$

so

$$B = 53.42^\circ \quad \text{or} \quad B = 180^\circ - 53.42^\circ = 126.58^\circ.$$

For $B = 53.42^\circ$, we have $C = 180^\circ - A - B = 91.58^\circ$.

Then from the Sine Rule (93), we get

$$c = a \frac{\sin C}{\sin A} = 5 \frac{0.9996}{0.5736} = 8.71 \text{ cm}.$$

For $B = 126.58^\circ$, we have $C = 180^\circ - A - B = 18.42^\circ$, and we get

$$c = a \frac{\sin C}{\sin A} = 5 \frac{0.316}{0.5736} = 2.75 \text{ cm}.$$

Summary

- | | |
|---------------------------------------|--|
| 1) Two angles and a side | $A + B + C = 180^\circ$ and Sine Rule. |
| 2) Three sides | Cosine Rule to get angles. |
| 3) Two sides and angle in between | Cosine Rule to get other side, then as for 2). |
| 4) Two sides and angle not in between | Sine Rules: two solutions in general. |

Example A.7.

$$a = 6 \text{ cm}, \quad c = 3 \text{ cm}, \quad B = 60^\circ.$$

This is case 3). Use the Cosine Rule (98). We have

$$b^2 = a^2 + c^2 - 2ac \cos B = 36 + 9 - 2 \times 6 \times 3 \times \frac{1}{2} = 27,$$

so

$$b = \sqrt{27} = 3\sqrt{3} = 5.1962.$$

We can get the other angles from the Cosine Rule:

$$a^2 = b^2 + c^2 - 2bc \cos A$$

so

$$\cos A = \frac{1}{2bc} (b^2 + c^2 - a^2) = \frac{1}{2 \times 5.1962 \times 3} (27 + 9 - 36) = 0.$$

This means that $A = 90^\circ$ and hence $B = 180^\circ - 90^\circ - 60^\circ = 30^\circ$.

Example A.8.

$$A = \frac{\pi}{3} = 60^\circ, \quad B = \frac{\pi}{2} = 90^\circ, \quad c = 20 \text{ cm.}$$

This is case 1). We have $C = \pi - A - B = \pi/6 = 30^\circ$. Now use the Sine Rule (93) to get the other sides.

$$a = c \frac{\sin A}{\sin C} = 20 \frac{0.866}{0.5} = 34.64 \text{ cm}, \quad b = c \frac{\sin B}{\sin C} = 20 \frac{1}{0.5} = 40 \text{ cm.}$$

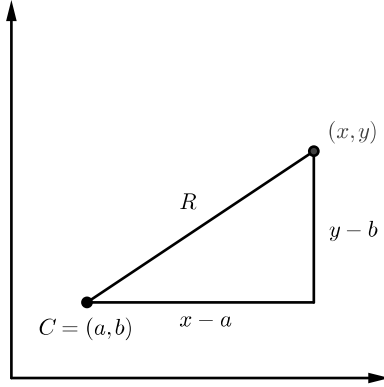

FIGURE 22. Distance in cartesian coordinates

A.4. Circles.

Definition A.9. The *circle* with the *centre* O and its *radius* R is all points on the plane which are at the distance R from O .

Let the centre O has Cartesian coordinates (a, b) . From the Pythagoras theorem (99), the circle's equation in the Cartesian coordinates is, see Fig. 22:

$$(100) \quad (x - a)^2 + (y - b)^2 = R^2.$$

Example A.10. Find the equation of the circle with centre $(2, -5)$ and radius 3. From (100), we have

$$(x - 2)^2 + (y + 5)^2 = 3^2 \quad \rightarrow \quad x^2 - 4x + y^2 + 10y = -20.$$

We can also find the centre and radius of a circle from its equation. We have

$$(x - a)^2 + (y - b)^2 = x^2 - 2ax + a^2 + y^2 - 2by + b^2.$$

Thus,

$$(x - a)^2 + (y - b)^2 = R^2 \quad \text{is equivalent to} \quad x^2 - 2ax + y^2 - 2by + (a^2 + b^2 - R^2) = 0.$$

So the coefficient of x gives $-2a$ and that of y $-2b$. For example, if the circle has equation

$$x^2 + y^2 - 16x + 12y = -19,$$

we have $a = 8, b = -6$. Then $R^2 - 64 - 36 = -19 \rightarrow R^2 = 81 \rightarrow R = 9$.

INDEX

- “long” logarithm, 34
- “tall” logarithm, 34

- absolute value, 14
- algorithm, 49
- anti-derivative, *see also* indefinite integral
- area, 3, 52
 - between two curves, 39
 - circle, of, 4, 37
 - ellipse, of, 38
 - paralillogram, 3
 - rectangle, 3
 - rectangle, of, 52
 - sphere, of, 42
 - triangle, 3
 - triangle, of, 53
 - under a graph, *see also* definite integral

- Barrow, 8
- binomial
 - coefficient
 - recurrence relation, 46
 - coefficients, 44
 - theorem, 47
- binomial coefficients, 47

- chain rule, 11
- change of variable
 - definite integral, 15
 - indefinite integral, 15
 - vs. integration by parts, 21
- choices, 44
- circle, 56
 - area, 4, 37
 - equation of, 56
- coefficient
 - binomial, 44, 47
 - recurrence relation, 46
- combinations, 44
- completing the square, 24
- constant
 - π , 3
 - Euler’s (e), 12
- Cosine rule, 54

- definite integral, 5
 - change of variable, 15
- degree
 - polynomial, of, 21
- discriminant, 24

- ellipse, 37
 - area, 38
- equation
 - circle, of, 56
- Euclid, 54
- Euler, 12
- Euler’s constant, 12
- even function, 31
- exponential function, 12

- factorial, 45
 - recurrence relation, 45
- fraction
 - partial, 22
- function
 - even, 31
 - exponential, 12
 - hyperbolic, 31
 - inverse, 14
 - logarithmic, 14
 - odd, 31
 - polynomial, 10
 - rational, 21
 - improper, 22
 - proper, 22
 - trigonometric, 53
- fundamental theorem of calculus, 9

- hyperbolic function, 31
- hyperbolic functions
 - inverse, 33

- improper rational function, 22
- indefinite integral, 10
 - change of variable, 15
- integral
 - definite, 5
 - indefinite, 10
 - Riemann, 7
- integration, 7
 - by parts, 19
 - vs. change of variable, 21
- trigonometric function, 11
- inverse function, 14
 - trigonometric, 28
- inverse hyperbolic functions, 33

- Jamshid al-Kashi, 54

- Lambert, 31
- Leibniz, 8
- logarithm, *see also* logarithmic function
 - “long”, 34
 - “tall”, 34
- logarithmic function, 14

- minomial, 21
- modulus, 14

- multiplication principle, 44
- Nasir al-Din al-Tusi, 53
- Newton, 8, 47
- odd function, 31
- Ostrogradsky, 22
- Ostrogradsky's method (integration of rational functions), 26
- paralillogram
 - area, 3
- partial fraction, 22
- Pascal, 47
- Pascal's triangle, 46
- permutations, 45
- polynomial, 21
 - degree, 21
 - quadratic, 24
 - completing the square, 24
 - discriminant, 24
- polynomial function, 10
- principle
 - multiplication, of, 44
- product
 - rule (combinatorics), 44
- proper rational function, 22
- Pythagoras theorem, 54
- quadratic polynomial, 24
 - completing the square, 24
 - discriminant, 24
- rational function, 21
 - Ostrogradsky's method of integration, 26
- rectangle
 - area, 3
- recurrence relation
 - binomial coefficients, 46
 - factorial, 45
- Riemann integral, 7
- rule
 - of product, 44
- Shen Kuo, 47
- Sine rule, 53
- sphere
 - area, 42
 - volume, 42
- substitution, *see also* change of variable
 - trigonometric, 27
- substitution, notation, 9
- theorem
 - binomial, 47
 - fundamental of calculus, 9
 - Pythagoras, 54
- triangle, 52
 - area, 3
 - area of, 53
 - Pascal's, 46
- trigonometric function, 53
 - integration, 11
 - inverse, 28
 - substitution, 27
- value
 - absolute, 14
- Vincenzo Riccati, 31
- volume
 - cone, of, 41
 - pyramid, of, 42
 - revolution, of, 41
 - ring, of, *see also* volume of torus
 - sphere, of, 42
 - torus, of, 43
- Weierstrass, 27
- Weierstrass substitution, *see also* trigonometric substitution

REFERENCES

- [1] Georg Polya, *How to solve it*, Doubleday Anchor Books, New York, 1957. ↑
- [2] Earl Swokowski, Michael Olinick, and Dennis Pence, *Calculus*, 6-th, PWS Publishing, Boston, 1994. ↑